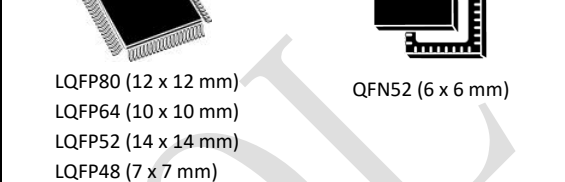

## Cortex-M4 core based MCU with 16 channel PWMs, 20 channel 14-bit ADC, 6 PGAs with Comparators

### Features

- ARM 32-bit Cortex-M4 CPU Core with FPU
    - 200 MHz maximum frequency
  - Memories
    - Up to 512 KB embedded flash
    - 512 Bytes OTP flash
    - Up to 80 KB on-chip SRAM (including 16 KB XIP-Cache)
  - Clock, reset and supply management
    - Single 3.3 V power supply
    - POR, Brown-out detector (BOD)
    - 1-to-66 MHz external crystal oscillator
    - Two internal 32MHz factory-trimmed RC
    - PLL for CPU clock
  - 6-channel DMA controller
  - 14-bit A/D converters (up to 20 channels)
    - As low as 140 ns conversion time
    - Conversion range: 0 to 3.65 V
    - Differential sample
    - Triple-sample and hold capability
    - Open/short detection for safety
    - Temperature sensor
  - Programmable gain amplifier (PGA)
    - 6 integrated internal PGAs
    - Programmable Gains  
Single-ended: 1, 2, 4, 8, 12, 16, 24, 32  
Differential: 2, 4, 8, 16, 24, 32, 48, 64
  - Analog comparator
    - 16 high-speed comparators
    - Output with digital deglitch filter
    - 6 DACs as reference
    - Out of range voltage protection
    - Phase comparison
- 

LQFP80 (12 x 12 mm)  
LQFP64 (10 x 10 mm)  
LQFP52 (14 x 14 mm)  
LQFP48 (7 x 7 mm)  
QFN52 (6 x 6 mm)
- PWM
    - 8 enhanced PWM modules
    - 16 PWM outputs in total
    - Flexible waveform generation with phase lead/lag control
    - All events can trigger ADC conversion
  - Up to 61 GPIO Pins
    - Configurable pull-up/pull-down resistors
    - Programmable digital input deglitch filter
  - Enhanced Capture Module (ECAP)
    - Flexible input capture pin
    - Four 32-bit capture registers
    - Capture and APWM mode selection
  - Debug mode
    - Serial wire debug (SWD) & JTAG interfaces
  - 6 Timers
    - Three 32-bit general-purpose timers
    - Two 32-bit watchdog timers
    - One SysTick timer 24-bit down-counter
  - Communication interfaces
    - Up to UART x 4 (3 implemented by SIO)
    - Up to SPI x 4 (3 implemented by SIO)
    - Up to I<sup>2</sup>C x 4 (3 implemented by SIO)

- (Some communication interfaces are implemented through Spintrol patented SIO technology)
- Security Modules
  - CRC x 1, AES x 1, 64-bit unique ID
- Operating temperature
  - Junction temperature: -40 to +125 °C
  - Ambient temperature: -40 to +105 °C

**Table 1-1: SPC1198 device features and peripheral counts**

Peripheral	SPC1198APE80	SPC1198(L)APE64	SPC1198APE52	SPC1198(L)APE48	SPC1198API52
Flash	512KB	512KB 256KB (L)	512KB	512KB 256KB (L)	512KB
OTP Flash	512Bytes	512Bytes	512Bytes	512Bytes	512Bytes
SRAM	80KB	80KB	80KB	80KB	80KB
DMA	1	1	1	1	1
Number of channels	6 channels	6 channels	6 channels	6 channels	6 channels
GPIOs <sup>(1)</sup>	61	49	42	38	40
14-bit ADC	1	1	1	1	1
Number of channels	20 channels	17 channels	16 channels	14 channels	18 channels
PGA	6	6	6	6	6
Analog comparators	16	16	16	16	16
DAC	6	6	6	6	6
PWM	8	8	8	8	8
Number of channels	16 channels	16 channels	12 channels	12 channels	10 channels
ECAP	1	1	1	1	1
General-purpose timers	3	3	3	3	3
Watchdog timers	2	2	2	2	2
AES	1	1	1	1	1
CRC	1	1	1	1	1
UART	1	1	1	1	1
SPI	1	1	1	1	1
I2C	1	1	1	1	1
SIO	3	3	3	3	3
Maximum CPU frequency	200MHz	200MHz	200MHz	200MHz	200MHz

[1] Not including GPIO47 (BOOT) pin.

# Contents

<b>1</b>	<b>Device overview</b>	<b>10</b>
<b>2</b>	<b>Feature descriptions</b>	<b>12</b>
2.1	ARM Cortex-M4 core with FPU	12
2.2	Embedded SRAM	12
2.3	Embedded Flash memory	12
2.4	Nested vectored interrupt controller (NVIC)	12
2.5	External interrupt/event controller	13
2.6	Power supply and Reset	13
2.7	Brown-out detector	13
2.8	Clocks	13
2.9	Boot mode	13
2.10	General-purpose IOs (GPIOs)	14
2.11	Direct memory access controller (DMAC)	14
2.12	Timers and watchdogs	14
2.13	UART	15
2.14	I <sup>2</sup> C	15
2.15	SPI	16
2.16	ADC	16
2.17	Temperature sensor	17
2.18	PGAs	17
2.19	Analog comparators	17
2.20	PWMs	18
2.21	ECAP	18
2.22	Cyclic redundancy check (CRC)	18
2.23	Advanced encryption standard (AES) engine	19
2.24	Serial wire JTAG debug port (SWJ-DP)	19
2.25	SIO	19
<b>3</b>	<b>Pinouts and pin description</b>	<b>20</b>
3.1	LQFP80	20
3.2	LQFP64	31
3.3	LQFP52	41
3.4	LQFP48	49
3.5	QFN52	56
3.6	PGA input channel selection	63
3.7	GPIO pin function and state after reset	64

<b>4</b>	<b>Memory mapping .....</b>	<b>66</b>
<b>5</b>	<b>Electrical characteristics .....</b>	<b>68</b>
5.1	Absolute maximum ratings .....	68
5.2	Recommended operating conditions .....	69
5.3	I/O Electrical characteristics .....	69
5.4	Power consumption summary .....	71
5.5	Internal 1.2V regulator characteristics .....	74
5.6	BOD characteristics .....	75
5.7	RCO characteristics .....	75
5.8	PLL characteristics .....	76
5.9	XO characteristics .....	76
5.10	14-bit ADC characteristics .....	81
5.11	PGA characteristics .....	82
5.12	Analog comparator characteristics .....	83
5.13	Internal 10-bit DAC characteristics .....	83
5.14	DAC buffer characteristics .....	83
5.15	Flash memory characteristics .....	84
5.16	Electrical sensitivity characteristics .....	84
5.17	Moisture sensitivity characteristics .....	85
5.18	Thermal resistance characteristics .....	85
5.19	SPI characteristics .....	86
<b>6</b>	<b>Package information .....</b>	<b>87</b>
6.1	LQFP80 .....	87
6.2	LQFP64 .....	89
6.3	LQFP52 .....	91
6.4	LQFP48 .....	93
6.5	QFN52 .....	95
<b>7</b>	<b>Ordering information .....</b>	<b>97</b>
7.1	Coding rule .....	97

## List of tables

Table 1-1: SPC1198 device features and peripheral counts .....	2
Table 3-1: SPC1198 LQFP80 pin definitions .....	20
Table 3-2: SPC1198 LQFP64 pin definitions .....	31
Table 3-3: SPC1198 LQFP52 pin definitions .....	41
Table 3-4: SPC1198 LQFP48 pin definitions .....	49
Table 3-5: SPC1198 QFN52 pin definitions.....	56
Table 3-6: PGA0/1/2 input channel selection .....	63
Table 3-7: PGA3/4/5 input channel selection .....	63
Table 3-8: GPIO pin function and state after reset.....	64
Table 5-1: Absolute maximum ratings <sup>(1)(2)</sup> .....	68
Table 5-2: Recommended operating conditions .....	69
Table 5-3: I/O Electrical characteristics .....	69
Table 5-4: SPC1198 typical current consumption (Run in FLASH).....	71
Table 5-5: SPC1198 typical current consumption (Run in RAM).....	72
Table 5-6: Peripheral current consumption .....	73
Table 5-7: Internal 1.2V regulator characteristics .....	74
Table 5-8: BOD characteristics .....	75
Table 5-9: RCO characteristics.....	75
Table 5-10: PLL characteristics .....	76
Table 5-11: XO characteristics .....	76
Table 5-12: ADC characteristics.....	81
Table 5-13: PGA characteristics.....	82
Table 5-14: Comparator characteristics .....	83
Table 5-15: DAC characteristics.....	83
Table 5-16: DAC buffer characteristics .....	83
Table 5-17: Flash memory characteristics.....	84
Table 5-18: ESD absolute maximum ratings.....	84
Table 5-19: Electrical sensitivities .....	84
Table 5-20: Moisture sensitivity characteristic .....	85
Table 5-21: Thermal resistance characteristics (LQFP80 package).....	85
Table 5-22: Thermal resistance characteristics (LQFP64 package).....	85
Table 5-23: Thermal resistance characteristics (LQFP52 package).....	85
Table 5-24: Thermal resistance characteristics (LQFP48 package).....	86
Table 5-25: Thermal resistance characteristics (QFN52 package).....	86
Table 5-26: SPI characteristics.....	86
Table 6-1: LQFP80 – 80 pin, 12 x 12 mm low-profile quad flat package mechanical data .....	87
Table 6-2: LQFP64 – 64 pin, 10 x 10 mm low-profile quad flat package mechanical data .....	89
Table 6-3: LQFP52 – 52 pin, 14 x 14 mm low-profile quad flat package mechanical data .....	91
Table 6-4: LQFP48 – 48 pin, 7 x 7 mm low-profile quad flat package mechanical data .....	93
Table 6-5: QFN52 – 52 pin, 6 x 6 mm quad flat no-lead package mechanical data .....	95
Table 7-1: Ordering information .....	97

## List of figures

Figure 1-1: Block diagram of SPC1198 .....	10
Figure 1-2: Clock tree .....	11
Figure 3-1: SPC1198 LQFP80 pinout .....	20
Figure 3-2: SPC1198 LQFP64 pinout .....	31
Figure 3-3: SPC1198 LQFP52 pinout .....	41
Figure 3-4: SPC1198 LQFP48 pinout .....	49
Figure 3-5: SPC1198 QFN52 pinout.....	56
Figure 4-1: SPC1198 memory map with Cache disabled .....	66
Figure 4-2: SPC1198 memory map with Cache enabled.....	67
Figure 5-1: Typical operational current versus frequency.....	72
Figure 5-2: Internal 1.2V regulator load regulation ( $T_A = 25^\circ\text{C}$ ).....	74
Figure 5-3: Internal 1.2V regulator load regulation with different temperature .....	74
Figure 5-4: The negative resistance of the on-chip crystal oscillator at $50^\circ\text{C}$ .....	77
Figure 5-5: The negative resistance of the on-chip crystal oscillator at $85^\circ\text{C}$ .....	78
Figure 5-6: The negative resistance of the on-chip crystal oscillator at $100^\circ\text{C}$ .....	79
Figure 5-7: The negative resistance of the on-chip crystal oscillator at $125^\circ\text{C}$ .....	80
Figure 5-8: DAC buffer offset over Input voltage .....	84
Figure 6-1: LQFP80 – 80 pin, 12 x 12 mm low-profile quad flat package outline .....	87
Figure 6-2: LQFP80 – 80 pin, 12 x 12 mm low-profile quad flat package recommended footprint.....	88
Figure 6-3: LQFP64 – 64 pin, 10 x 10 mm low-profile quad flat package outline .....	89
Figure 6-4: LQFP64 – 64 pin, 10 x 10 mm low-profile quad flat package recommended footprint.....	90
Figure 6-5: LQFP52 – 52 pin, 14 x 14 mm low-profile quad flat package outline .....	91
Figure 6-6: LQFP52 – 52 pin, 14 x 14 mm low-profile quad flat package recommended footprint.....	92
Figure 6-7: LQFP48 – 48 pin, 7 x 7 mm low-profile quad flat package outline .....	93
Figure 6-8: LQFP48 – 48 pin, 7 x 7 mm low-profile quad flat package recommended footprint.....	94
Figure 6-9: QFN52 – 52 pin, 6 x 6 mm quad flat no-lead package outline.....	95
Figure 6-10: QFN52 – 52 pin, 6 x 6 mm quad flat no-lead package recommended footprint .....	96
Figure 7-1: Coding rule.....	97

## Revision history

Revision	Date	Author	Status	Changes
1	2019-04-01	-	Outdated	1. Initial version.
2	2019-08-16	-	Outdated	1. Modifies JTAG pin description in Table 3-1.
3	2019-12-20	-	Outdated	1. Add <a href="#">Table 5-18</a> . 2. Add <a href="#">Table 5-19</a> .
4	2020-05-12	-	Outdated	1. Update <a href="#">Section 2.9</a> for boot mode description. 2. Update <a href="#">Section 2.15</a> and modify the maximum speed of SPI. 3. Update <a href="#">Table 5-3</a> . 4. Update <a href="#">Table 5-7</a> . 5. Update <a href="#">Figure 5-2</a> . 6. Add <a href="#">Table 5-8</a> . 7. Add <a href="#">Table 5-9</a> . 8. Add <a href="#">Table 5-10</a> . 9. Add <a href="#">Table 5-11</a> . 10. Update <a href="#">Table 5-12</a> . 11. Add <a href="#">Table 5-21</a> . 12. Add <a href="#">Table 5-26</a> .
5	2020-05-22	-	Outdated	1. Update <a href="#">Section 2.19</a> for phase comparison. 2. Add <a href="#">Figure 3-2</a> . 3. Add <a href="#">Table 3-2</a> . 4. Add <a href="#">Figure 3-5</a> . 5. Add <a href="#">Table 3-5</a> . 6. Add <a href="#">Figure 6-3</a> . 7. Add <a href="#">Table 6-2</a> . 8. Add <a href="#">Figure 6-4</a> . 9. Add <a href="#">Figure 6-9</a> . 10. Add <a href="#">Table 6-5</a> . 11. Add <a href="#">Table 7-1</a> .
6	2020-07-06	-	Outdated	1. Update <a href="#">Section 2.9</a> for boot mode description. 2. Update <a href="#">Section 2.13</a> for UART features. 3. Update <a href="#">Section 2.22</a> for CRC features. 4. Update <a href="#">Table 5-13</a> and modify the value of $R_{IN}$ parameter.
7	2020-07-31	-	Outdated	1. Add <a href="#">Figure 5-3</a> . 2. Update <a href="#">Table 5-13</a> . 3. Update <a href="#">Table 5-17</a> .
8	2020-10-08	-	Outdated	1. Update <a href="#">Table 5-3</a> .

Revision	Date	Author	Status	Changes
				<ul style="list-style-type: none"> <li>2. Add characteristics of ambient temperature <math>T_A</math>.</li> <li>3. Update <a href="#">Section 2.13</a> for UART features.</li> <li>4. Update <a href="#">Table 5-13</a>.</li> </ul>
9	2021-03-28	-	Outdated	<ul style="list-style-type: none"> <li>1. Add current data for low and high temperature in <a href="#">Table 5-4</a>, <a href="#">Table 5-5</a> and <a href="#">Table 5-6</a>.</li> <li>2. Add <a href="#">Figure 6-10</a>.</li> <li>3. Add SPC1198 LQFP52 pin description and package information.</li> <li>4. Add SPC1198 LQFP48 pin description and package information.</li> <li>5. Update <a href="#">Figure 3-2</a>.</li> <li>6. Update comparator pin descriptions in <a href="#">Table 3-1</a> ~ <a href="#">Table 3-5</a>.</li> <li>7. Add <a href="#">Table 3-6</a> and <a href="#">Table 3-7</a>.</li> <li>8. Add <a href="#">Table 3-8</a>.</li> <li>9. Add note for <a href="#">Table 5-4</a>.</li> <li>10. Add note for <a href="#">Table 5-5</a>.</li> <li>11. Update <a href="#">Table 5-6</a>.</li> <li>12. Update chip communication interface features.</li> <li>13. Update <a href="#">Figure 3-1</a> and its notes.</li> <li>14. Update <a href="#">Figure 3-2</a> and its notes.</li> <li>15. Update <a href="#">Figure 3-3</a> and its notes.</li> <li>16. Update <a href="#">Figure 3-4</a> and its notes.</li> <li>17. Update <a href="#">Figure 3-5</a> and its notes.</li> </ul>
10	2021-11-27	-	Outdated	<ul style="list-style-type: none"> <li>1. Add <a href="#">Table 1-1</a>.</li> <li>2. Add <a href="#">Table 5-20</a>.</li> <li>3. Update <a href="#">Table 3-6</a>.</li> <li>4. Update <a href="#">Section 2.11</a>.</li> <li>5. Update <a href="#">Table 5-14</a>.</li> <li>6. Add <a href="#">Figure 5-4</a>.</li> <li>7. Add <a href="#">Figure 5-5</a>.</li> <li>8. Add <a href="#">Figure 5-6</a>.</li> <li>9. Add <a href="#">Figure 5-7</a>.</li> <li>10. Update <a href="#">Table 3-1</a>, modify the description for debug pins.</li> <li>11. Update <a href="#">Table 3-2</a>, modify the description for debug pins.</li> <li>12. Update <a href="#">Table 3-3</a>, modify the description for debug pins.</li> <li>13. Update <a href="#">Table 3-4</a>, modify the description for debug pins.</li> </ul>



Revision	Date	Author	Status	Changes
				14. Update <a href="#">Table 3-5</a> , modify the description for debug pins. 15. Update deep-sleep current consumption value in <a href="#">Table 5-4</a> .
11	2022-11-16	-	Outdated	1. Update <a href="#">Section 2.22</a> . 2. Update <a href="#">Table 5-3</a> , remove parameter $I_{OZ}$ . 3. Update Figure 4-1. 4. Update Figure 4-2. 5. Update Figure 1-1. 6. Update <a href="#">Table 7-1</a> . 7. Update <a href="#">Section 2.9</a> and <a href="#">Section 2.10</a> . 8. Update Conditions of parameter $R_{PU}$ and $R_{PD}$ in <a href="#">Table 5-3</a> . 9. Update <a href="#">Table 3-6</a> . 10. Update <a href="#">Table 3-7</a> . 11. Update <a href="#">Section 2.6</a> .
A/0	2024-01-13	-	Outdated	1. Update <a href="#">Section 3.4</a> . 2. Update the document style.
C/0	2024-08-09	Jiali Zhou	Outdated	1. Update the document style. 2. Update <a href="#">Section 2.13</a> . 3. Add ordering information. 4. Update Table 5-17 parameter symbols, increase programming entry and exit time.
C/1	2024-09-26	Jiali Zhou	Released	1. Add LQFP64, LQFP52, LQFP48, QFN52 package thermal resistance characteristics. 2. Correct some clerical errors.

# 1 Device overview

The SPC1198 device from Spintrol is a high performance and integration system-on-chip (SOC) microcontroller. The SPC1198 incorporates a 32-bit ARM Cortex-M4 high-performance processors with a software-programmable clock rate as high as 200 MHz, 80 KB SRAM, embedded flash with 512 KB, and an extensive range of enhanced I/Os and peripherals. [Figure 1-1](#) shows the functional block diagram for the SPC1198.

**Figure 1-1: Block diagram of SPC1198**

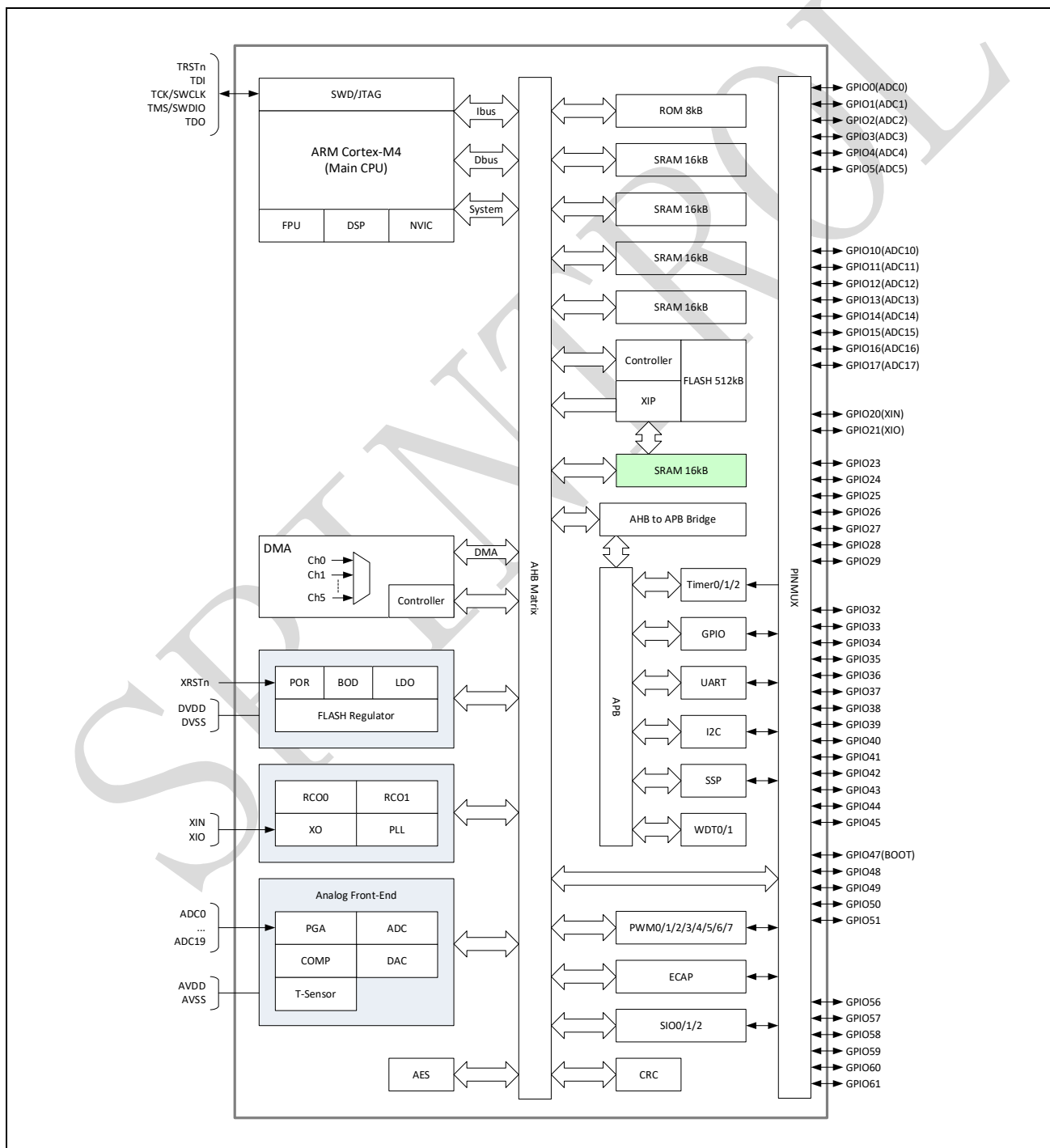

The Direct Memory Access Controller (DMAC) is used to provide high-speed data transfer between peripherals and memory as well as memory to memory. Data can be quickly moved by DMAC without any CPU actions. This keeps CPU resources free for other operations.

The SPC1198 device offers a 14-bit ADC, 6 PGAs, 8 enhanced PWMs, 3 general purpose 32-bit timers, as well as standard and advanced communication interface: UART, I<sup>2</sup>C and SPI. These features make the SPC1198 ideal for motion control application.

The SPC1198 operates from a 2.97 to 3.63 V power supply. The temperature range is from -40 °C to +125 °C temperature range. The package type can be 80-pin LQFP, 64-pin LQFP, 48-pin LQFP or 52-pin QFN/LQFP.

Figure 1-2 shows the clock tree information.

Figure 1-2: Clock tree

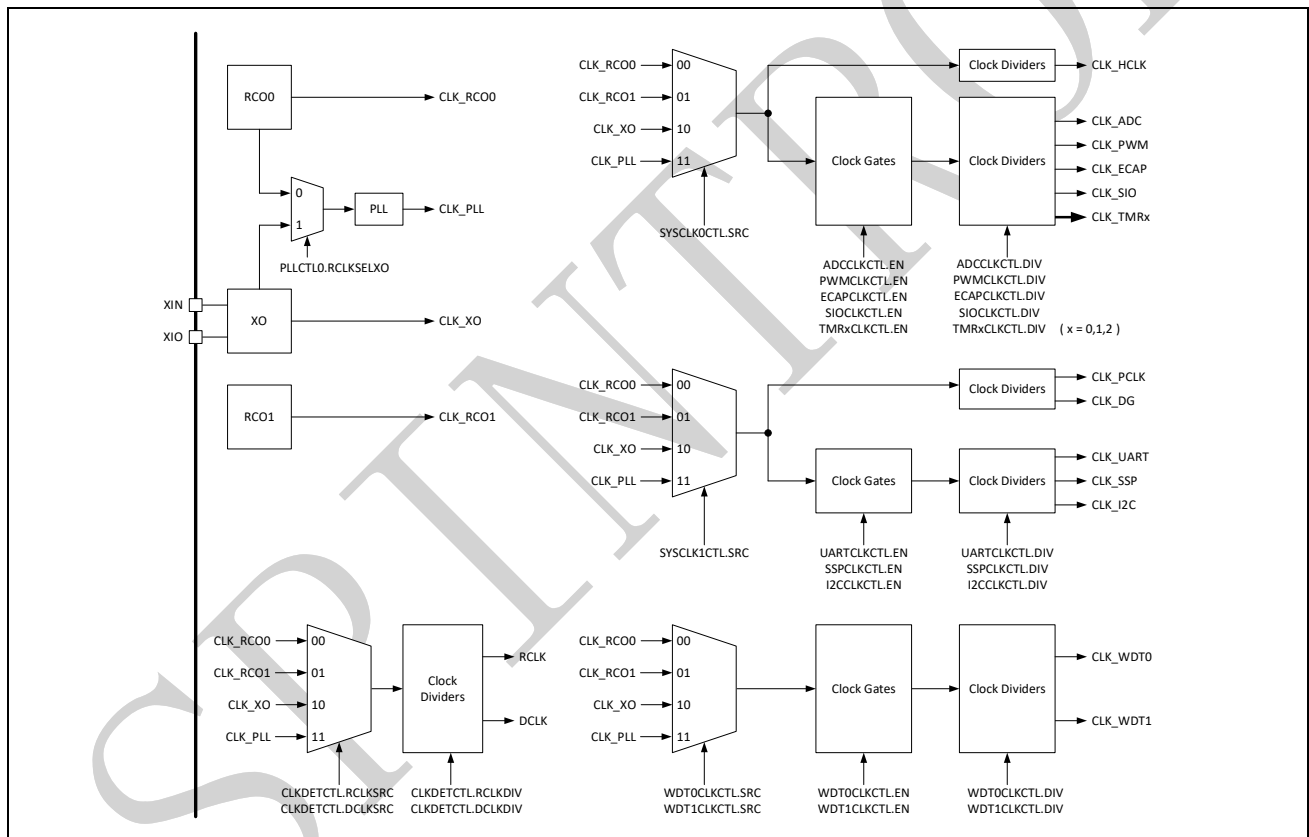

## 2 Feature descriptions

### 2.1 ARM Cortex-M4 core with FPU

The ARM Cortex-M4 processor has been developed to provide a low-cost platform that meets the needs of MCU implementation, with a reduced pin count and low-power consumption, while delivering outstanding computational performance and an advanced system response to interrupts.

The SPC1198 integrates a full-feature ARM Cortex-M4 core with FPU that can run up to 200MHz. Therefore, it is compatible with all ARM tools and software.

### 2.2 Embedded SRAM

The SPC1198 has implemented 80KB (include 16 KB Flash XIP cache) SRAM memory for code and data. The SRAM can be accessed (read/write) at CPU clock speed with 0 wait states. A 16KB storage unit can be used as Flash XIP cache or SRAM.

### 2.3 Embedded Flash memory

Up to 512 KB of embedded Flash memory is available for storing code and data.

### 2.4 Nested vectored interrupt controller (NVIC)

Each CPU in SPC1198 embeds a nested vectored interrupt controller able to handle up to 63 maskable interrupt channels (not including the 16 interrupt lines of Cortex-M4) and 16 programmable priority levels.

- Closely coupled NVIC gives low-latency interrupt processing
- Interrupt entry vector table address passed directly to the core
- Processing of *late arriving* higher priority interrupts
- Support for tail-chaining
- Support for lazy-stacking
- Interrupt entry restored on interrupt exit with no instruction overhead

## 2.5 External interrupt/event controller

The SPC1198 provides a flexible external pin interrupt or event trigger mechanism. Any GPIO pin can be programmed as an external interrupt or event trigger source. In addition, any GPIO interrupt can be configured as edge-triggered or level-triggered.

## 2.6 Power supply and Reset

The SPC1198 supports nominal 3.3V single power supply, which powers the IOs, internal voltage regulators and analog circuitry on chip. Supply ramp-up rate less than or equal  $1.5 \times 10^4$  V/s.

The SPC1198 has a global reset pin as well as an integrated power-on reset (POR) circuitry. The POR circuitry guarantees all power-up reset sequence requirements and makes the device easy to use.

## 2.7 Brown-out detector

The device features an embedded brown-out detector (BOD) that monitors the 3.3V/1.2V domain power supply and compare it to the programmable pre-set value. An interrupt or reset can be generate when voltage of the power domain is higher or drops below the pre-set value. The interrupt service routine then generate a warning message and/or put the MCU into a safe state. The BOD is enabled by software.

## 2.8 Clocks

System clock selection is performed on startup. The internal 32 MHz RC oscillator is selected by default upon reset. An external 1 - 66 MHz oscillator can be selected by the user.

The device implements a fractional phase-lock loop (PLL) for high frequency clock generation. The PLL can take the internal RC oscillator or external clock as the input reference clock. The output frequency covers from 25MHz to 200MHz.

Several clock dividers allow the configuration of the AHB, APB and the peripherals frequency. The maximum allowed frequency is 200MHz for AHB and 50 MHz for APB. See Figure 1-2 for details on the clock tree.

## 2.9 Boot mode

The boot code is located in on-chip ROM memory. After reset, the ARM processor begins code execution from this ROM. The boot pin and TRSTn pin are used to select one of the two boot options:

- Boot from embedded Flash (boot pin = 1, TRSTn pin = X): the boot loader jumps to the embedded Flash and runs from the address at 0x1000 0000

- ISP mode (boot pin = 0, TRSTn pin = 0): the boot loader reprograms the embedded Flash by using UART. During the process, for chip with LQFP48 or QFN52 package, the GPIO38 is configured as UART\_TXD and the GPIO39 is configured as UART\_RXD; for chip with other packages, the GPIO44 is configured as UART\_TXD and the GPIO45 is configured as UART\_RXD.

- 
- Note:
- The boot pin should always keep high when chip normally running.
  - The TRSTn pin is recommended to set as low.
  - When TRSTn is high, the related debug interface pins (GPIO48 ~ GPIO51) must not be used as GPIO function.
- 

## 2.10 General-purpose IOs (GPIOs)

The SPC1198 can be configured to support as many as 61 multi-purpose GPIO pins. Each GPIO pin can be configured by software as input, as output or as peripheral alternate function. It features:

- Each GPIO pin has configurable internal pull-up and pull-down resistors
- Each GPIO pin has a programmable digital input deglitch filter

## 2.11 Direct memory access controller (DMAC)

The DMA controller in SPC1198 has 6 channels in total to manage memory access requests from one or more peripherals. It has an arbiter for handling the priority between DMA requests. The DMA controller is interconnected with DRAM through the AHB bus matrix as well as APB peripherals (UART and SSP) through AHB-to-APB bridge. It features:

- 6 independently configurable channels and each channel FIFO depth is 16 x 32 bits
- Programmable transfer type for each channel: memory-to-memory, memory-to-peripheral and peripheral-to-memory
- Programmable source and destination addresses: address increment, decrement, or no change.
- Single block transfer with configurable block size up to 4095 words (32 bits)
- 4 configurable hardware handshaking interfaces

## 2.12 Timers and watchdogs

The SPC1198 device includes three general-purpose timers, two watchdog timers and one SysTick timer.

### General-purpose timers

The SPC1198 includes three identical 32-bit general-purpose timers. Each general-purpose timer consists of a 32-bit auto-reload down-counter. An interrupt would be generated when the counter

reaches zero if it is enabled. When the counter reaches zero, the timer can also generate an ADCSOC event or a PWMSYNC event if they are enabled. The clock of general-purpose timer can be selected from internal RC oscillators, external oscillator or PLL clock. Besides, each general-purpose timer can also capture external input as timer clock or enable signal.

### Watchdogs

The SPC1198 implements two identical watchdogs. Each watchdog is based on a 32-bit down-counter, which can be clocked from internal RC oscillators, external oscillator or PLL clock. When the counter reaches the given time-out value, an interrupt or a reset can be generated. The watchdog counter can be frozen or free-running in debug mode.

### SysTick Timer

This timer is dedicated for OS, but could also be used as a standard down-counter. It features:

- A 24-bit down-counter
- Auto-reload capability
- Mask-able system interrupt generation when the counter reaches 0

## 2.13 UART

The SPC1198 has an UART module. It features:

- Ability to add or delete standard asynchronous communication bits (start, stop and parity) in the serial data
- 5~8 data bits
- Even, odd or no parity detection
- One, one-and-a-half, or two stop bits generation
- Baud-rate generation up to 12.5 Mbps
- 64-byte transmit FIFO
- 64-byte receive FIFO
- Auto baud-rate detection

## 2.14 I<sup>2</sup>C

The I<sup>2</sup>C bus interface complies with the common I<sup>2</sup>C protocol and can operate in standard mode (with data rates up to 100 Kb/s) and fast mode (with data rates up to 400 Kb/s). It features:

- Three speeds: Standard mode (100 Kb/s), Fast mode (400 Kb/s) and High-Speed mode (2 Mb/s)
- Clock synchronization

- Master or slave I<sup>2</sup>C operation
- 7- or 10-bit addressing
- 7- or 10-bit combined format transfers
- 16 x 32-bit deep transmit and receive buffers, respectively

## 2.15 SPI

The SPI allows half/full-duplex, synchronous, serial communication with external devices. It features:

- Full-duplex synchronous transfers
- Master or slave operation
- 1 to 32-bit transfer frame format selection
- 50 Mbps maximum communication speed
- MSB-first data order
- Programmable clock polarity and phase
- Transmit and receive FIFOs

## 2.16 ADC

One 14-bit analog-to-digital converter is embedded into SPC1198 and has up to 20 external channels. The temperature sensor, internal powers and PGA outputs can be selected as ADC input channels. These inputs are multiplexed. The ADC core has three independent built-in sample-and-hold (S/H). Each S/H has two input channels, which is suitable for differential sampling.

The events generated by the general-purpose timers and the PWM outputs can be internally connected to the ADC start trigger.

- 14-bit resolution
- 140 ns minimum conversion time and independent configurable sampling time
- Differential sampling
- Triple-sample and hold capability
- Simultaneous sampling and sequential sampling modes supported
- Full range analog input: 0 V to 3.65 V
- Reference voltage can be selected from internal or external
- Input short and disconnection detection for safety



Please see [Table 5-12](#) for ADC characteristics.

## 2.17 Temperature sensor

The temperature sensor generates a voltage that varies linearly with temperature. It is internally connected to the ADC input channel, which is used to convert the sensor output voltage into a digital value.

## 2.18 PGAs

Six flexible programmable gain amplifiers (PGAs) are embedded into SPC1198 and shares up to 20 channels. The temperature sensor and internal 1.2V power can be selected as a PGA input channels. These inputs are multiplexed. Each PGA outputs are connected to ADC input channel.

- Programmable gains  
Differential mode: 2, 4, 8, 16, 24, 32, 48, 64; Single-ended mode: 1, 2, 4, 8, 12, 16, 24, 32.
- Settling time: 400 ns to 800 ns

Please see [Table 5-13](#) for PGA characteristics.

## 2.19 Analog comparators

The SPC1198 has sixteen high-speed comparators. Each comparator use the internal DAC as reference for monitoring PGA inputs or outputs. Two comparators are designed for each PGA: one is monitoring too-high voltage, the other is monitoring too-low voltage. The extra two pairs of comparators are reserved for additional applications. The comparator output is routed to the PWM Trip-Zone modules. Additionally, each comparator can implement the phase comparison for motor commutation. The detail channel selection can be referred to Technical Reference Manual.

- 50 ns typical response
- Programmable hysteresis
- Output with digital deglitch filter
- Phase comparison

Please see [Table 5-14](#) and [Table 5-15](#) for analog comparator and DAC characteristics.

## 2.20 PWMs

The SPC1198 integrates eight PWM modules and supports 16 PWM channels. Without much involvement of processor core, the PWMs can generate complex pulse width waveforms.

Each PWM module supports the following features:

- Dedicated 16-bit time-base counter with period and frequency control
- Each PWM module can generate two outputs with single-edge operation, dual-edge symmetric operation or dual-edge asymmetric operation
- All events can trigger both CPU interrupts and ADC start of conversion
- Programmable phase-control support for lag or lead operation relative to other PWM modules
- Dead-band generation with independent rising and falling edge delay control
- Programmable trip zone allocation of both cycle-by-cycle trip and one-shot trip on fault conditions
- A trip condition can force either high, low, or high-impedance state logic levels at PWM outputs
- Comparator module outputs and trip zone inputs can generate events, filtered events, or trip conditions

## 2.21 ECAP

The enhanced capture (ECAP) module is essential in systems where accurate timing of external events is important. The SPC1198 has implemented an ECAP module with following features:

- Flexible input capture pin: each GPIO can be configured as capture pin
- 32-bit time base counter
- 4 x 32-bit time-stamp capture registers
- 4-stage sequencer that is synchronized to external events
- Independent edge polarity (rising/falling edge) selection for all 4 events
- Interrupt capabilities on any of the 4 capture events

## 2.22 Cyclic redundancy check (CRC)

The SPC1198 has a hardware CRC calculation unit. The CRC module is used to verify data transmission or storage integrity. It features:

- 32-bit parallel bit stream input, and up to 32-bit CRC output

- Supports up to  $2^{32}$  byte length for CRC calculation
- Five CRC standard polynomials supported

### 2.23 Advanced encryption standard (AES) engine

The AES engine provides fast hardware encryption and decryption services. The main features are as follows:

- Supports as many as six block cipher modes: ECB, CBC, CTR, CCM\*, MMO, and Bypass
- Supports 128-, 192-, and 256-bits key size
- Error indication for each block cipher mode
- Separate 4 x 32-bit input and output FIFOs

### 2.24 Serial wire JTAG debug port (SWJ-DP)

The ARM SWJ-DP interface is embedded and is a combined JTAG and serial wire debug port. The SWJ-DP interface enables either a serial wire debug or a JTAG probe to be connected to the target. The debug port can be disabled when enabling SPC1198 certain security feature. Dual SWD interfaces can be enabled for ease of the main CPU and CAU co-debug.

### 2.25 SIO

SIO is a Spintrol patented technology. It has programmable capability which can convert the SIO block into pre-defined communication module. Currently the SIO can be used as UART, SPI, I2C and CAN once it is programmed through initialization. There will be more features added in short time. In SPC1198, three SIO blocks has been implemented.

### 3 Pinouts and pin description

#### 3.1 LQFP80

Figure 3-1: SPC1198 LQFP80 pinout

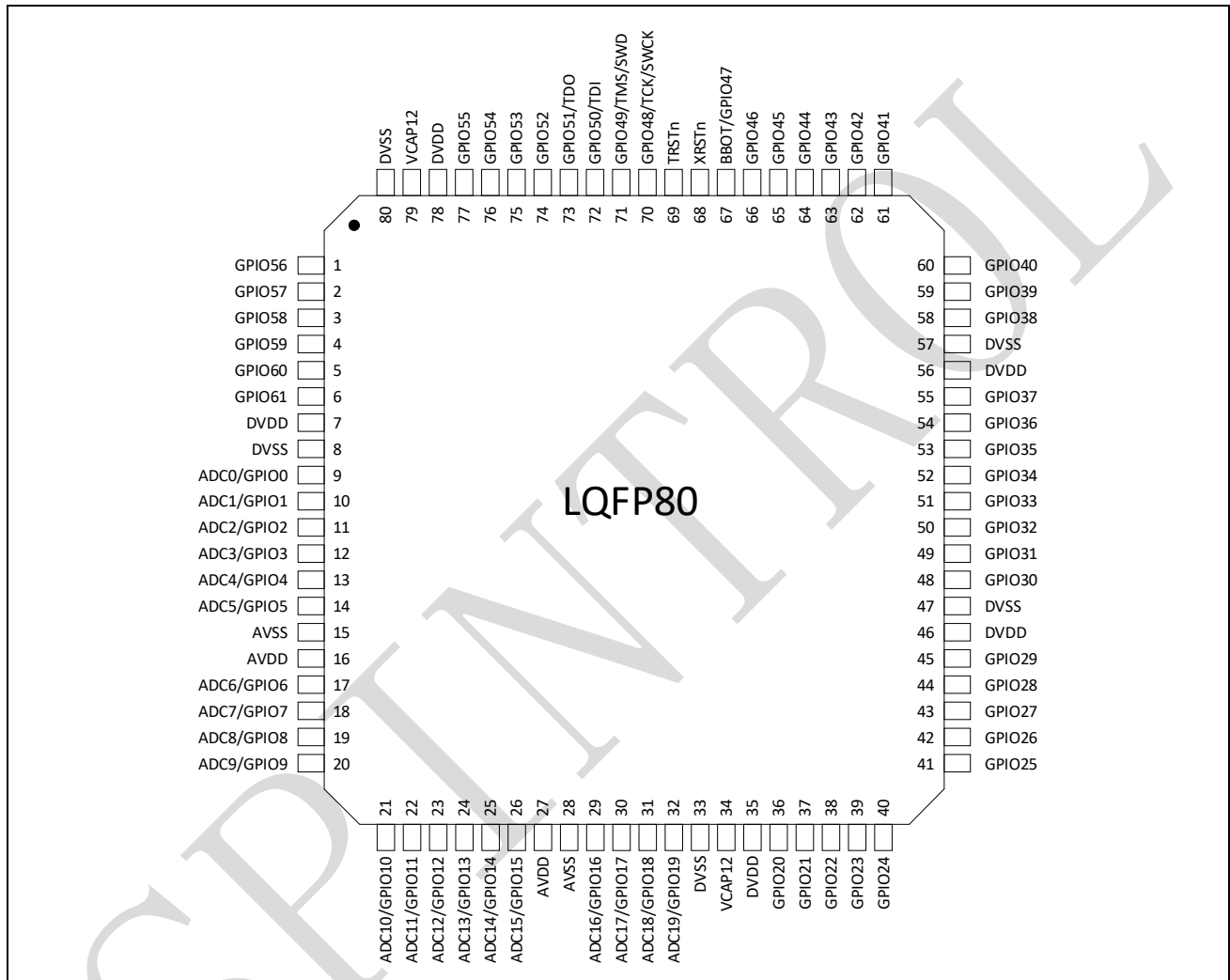

- [1] The above figure shows the package top view.
- [2] **Note:** there is no need to connect the two VCAP12 pins on the PCB boards.
- [3] **Note:** when TRSTn is HIGH, GPIO48 ~ GPIO51 pins work as Debug interface and can't be configured as other functions.

Table 3-1: SPC1198 LQFP80 pin definitions

Pin	Signal	Type <sup>(1)</sup>	Description
1	GPIO56	I/O	General-purpose input/output 56
	PWM4A	O	PWM4 output A
	SIO2_12	I/O	SIO2 input/output 12
2	GPIO57	I/O	General-purpose input/output 57

Pin	Signal	Type <sup>(1)</sup>	Description
	PWM5A	O	PWM5 output A
	PWM4B	O	PWM4 output B
	SIO2_13	I/O	SIO2 input/output 13
3	GPIO58	I/O	General-purpose input/output 58
	PWM6A	O	PWM6 output A
	PWM5A	O	PWM5 output A
	SIO2_14	I/O	SIO2 input/output 14
4	GPIO59	I/O	General-purpose input/output 59
	PWM4B	O	PWM4 output B
	PWM5B	O	PWM5 output B
	SIO2_15	I/O	SIO2 input/output 15
5	GPIO60	I/O	General-purpose input/output 60
	PWM5B	O	PWM5 output B
	PWM6A	O	PWM6 output A
	SIO2_16	I/O	SIO2 input/output 16
6	GPIO61	I/O	General-purpose input/output 61
	PWM6B	O	PWM6 output B
	SIO2_17	I/O	SIO2 input/output 17
7	DVDD	S	Digital power, add 0.1uF bypass ceramic cap to DVSS
8	DVSS	S	Digital ground
9	GPIO0	I/O	General-purpose input/output 0
	ADC0	AI	ADC channel 0 input
	COMP0H	O	Comparator COMP0H result output
	SIO0_0	I/O	SIO0 input/output 0
10	GPIO1	I/O	General-purpose input/output 1
	ADC1	AI	ADC channel 1 input
	COMP0L	O	Comparator COMP0L result output
	SIO0_1	I/O	SIO0 input/output 1
11	GPIO2	I/O	General-purpose input/output 2
	ADC2	AI	ADC channel 2 input
	COMP1H	O	Comparator COMP1H result output

Pin	Signal	Type <sup>(1)</sup>	Description
	SIO0_2	I/O	SIO0 input/output 2
12	GPIO3	I/O	General-purpose input/output 3
	ADC3	AI	ADC channel 3 input
	COMP1L	O	Comparator COMP1L result output
	SIO0_3	I/O	SIO0 input/output 3
13	GPIO4	I/O	General-purpose input/output 4
	ADC4	AI	ADC channel 4 input
	COMP2H	O	Comparator COMP2H result output
	SIO0_4	I/O	SIO0 input/output 4
14	GPIO5	I/O	General-purpose input/output 5
	ADC5	AI	ADC channel 5 input
	COMP2L	O	Comparator COMP2L result output
	SIO0_5	I/O	SIO0 input/output 5
15	AVSS	S	Analog ground
16	AVDD	S	Analog power, add 4.7uF and 0.1uF bypass ceramic cap to AVSS
17	GPIO6	I/O	General-purpose input/output 6
	ADC6	AI	ADC channel 6 input
	SIO0_6	I/O	SIO0 input/output 6
18	GPIO7	I/O	General-purpose input/output 7
	ADC7	AI	ADC channel 7 input
	SIO0_7	I/O	SIO0 input/output 7
19	GPIO8	I/O	General-purpose input/output 8
	ADC8	AI	ADC channel 8 input
	SIO0_8	I/O	SIO0 input/output 8
20	GPIO9	I/O	General-purpose input/output 9
	ADC9	AI	ADC channel 9 input
	SIO0_9	I/O	SIO0 input/output 9
21	GPIO10	I/O	General-purpose input/output 10
	ADC10	AI	ADC channel 10 input
	COMP3H	O	Comparator COMP3H result output

Pin	Signal	Type <sup>(1)</sup>	Description
	SIO0_10	I/O	SIO0 input/output 10
22	GPIO11	I/O	General-purpose input/output 11
	ADC11	AI	ADC channel 11 input
	COMP3L	O	Comparator COMP3L result output
	DCLK	O	Clock output from CLKDET module for monitoring
	SIO0_11	I/O	SIO0 input/output 11
23	GPIO12	I/O	General-purpose input/output 12
	ADC12	AI	ADC channel 12 input
	COMP4H	O	Comparator COMP4H result output
	SIO0_12	I/O	SIO0 input/output 12
24	GPIO13	I/O	General-purpose input/output 13
	ADC13	AI	ADC channel 13 input
	COMP4L	O	Comparator COMP4L result output
	SIO0_13	I/O	SIO0 input/output 13
25	GPIO14	I/O	General-purpose input/output 14
	ADC14	AI	ADC channel 14 input
	COMP5H	O	Comparator COMP5H result output
	SIO0_14	I/O	SIO0 input/output 14
26	GPIO15	I/O	General-purpose input/output 15
	ADC15	AI	ADC channel 15 input
	COMP5L	O	Comparator COMP5L result output
	SIO0_15	I/O	SIO0 input/output 15
27	AVDD	S	Analog power, add 4.7uF and 0.1uF bypass ceramic cap to AVSS
28	AVSS	S	Analog ground
29	GPIO16	I/O	General-purpose input/output 16
	ADC16	AI	ADC channel 16 input
	COMP6H	O	Comparator COMP6H result output
	SIO0_16	I/O	SIO0 input/output 16
30	GPIO17	I/O	General-purpose input/output 17
	ADC17	AI	ADC channel 17 input

Pin	Signal	Type <sup>(1)</sup>	Description
	COMP6L	O	Comparator COMP6L result output
	SIO0_17	I/O	SIO0 input/output 17
31	GPIO18	I/O	General-purpose input/output 18
	ADC18	AI	ADC channel 18 input
	COMP7H	O	Comparator COMP7H result output
	SIO0_0	I/O	SIO0 input/output 0
32	GPIO19	I/O	General-purpose input/output 19
	ADC19	AI	ADC channel 19 input
	COMP7L	O	Comparator COMP7L result output
	SIO0_1	I/O	SIO0 input/output 1
33	DVSS	S	Digital ground
34	VCAP12	S	1.2V power, add 2.2uF bypass ceramic cap to DVSS
35	DVDD	S	Digital power, add 4.7uF and 0.1uF ceramic cap to DVSS
36	GPIO20	I/O	General-purpose input/output 20
	XIN	AI	External oscillator input
	SPI_SCLK	I/O	SPI clock input/output
	I2C_SCL	I/O	I <sup>2</sup> C clock
	UART_TXD	O	UART transmit data
	PWMSYNCO	O	PWMSYNCO signal output for monitoring
	SIO0_2	I/O	SIO0 input/output 2
37	GPIO21	I/O	General-purpose input/output 21
	XIO	AI/O	External oscillator input or output
	SPI_SFRM	I/O	SPI frame signal
	I2C_SDA	I/O	I <sup>2</sup> C data
	UART_RXD	I	UART receive data
	PWMSOC <sup>(2)</sup>	O	PWM SOC signal output for monitoring
	SIO0_3	I/O	SIO0 input/output 3
38	GPIO22	I/O	General-purpose input/output 22
	SPI_MOSI	I/O	SPI master output, slave input
	SPI_MISO	I/O	SPI master input, slave output
	SIO0_4	I/O	SIO0 input/output 4



Pin	Signal	Type <sup>(1)</sup>	Description
39	GPIO23	I/O	General-purpose input/output 23
	SPI_MISO	I/O	SPI master input, slave output
	SPI_MOSI	I/O	SPI master output, slave input
	SIO0_5	I/O	SIO0 input/output 5
40	GPIO24	I/O	General-purpose input/output 24
	COMP0H	O	Comparator COMP0H result output
	PWM1A	O	PWM1 output A
	SIO0_6	I/O	SIO0 input/output 6
41	GPIO25	I/O	General-purpose input/output 25
	COMP0L	O	Comparator COMP0L result output
	PWM2A	O	PWM2 output A
	PWM1B	O	PWM1 output B
	SIO0_7	I/O	SIO0 input/output 7
42	GPIO26	I/O	General-purpose input/output 26
	COMP1H	O	Comparator COMP1H result output
	PWM3A	O	PWM3 output A
	PWM2A	O	PWM2 output A
	SIO1_0	I/O	SIO1 input/output 0
43	GPIO27	I/O	General-purpose input/output 27
	COMP1L	O	Comparator COMP1L result output
	PWM1B	O	PWM1 output B
	PWM2B	O	PWM2 output B
	SIO1_1	I/O	SIO1 input/output 1
44	GPIO28	I/O	General-purpose input/output 28
	COMP2H	O	Comparator COMP2H result output
	PWM2B	O	PWM2 output B
	PWM3A	O	PWM3 output A
	SIO1_2	I/O	SIO1 input/output 2
45	GPIO29	I/O	General-purpose input/output 29
	COMP2L	O	Comparator COMP2L result output
	PWM3B	O	PWM3 output B

Pin	Signal	Type <sup>(1)</sup>	Description
	SIO1_3	I/O	SIO1 input/output 3
46	DVDD	S	Digital power, add 0.1uF bypass ceramic cap to DVSS
47	DVSS	S	Digital ground
48	GPIO30	I/O	General-purpose input/output 30
	I2C_SCL	I/O	I <sup>2</sup> C clock
	SIO1_4	I/O	SIO1 input/output 4
49	GPIO31	I/O	General-purpose input/output 31
	I2C_SDA	I/O	I <sup>2</sup> C data
	SIO1_5	I/O	SIO1 input/output 5
50	GPIO32	I/O	General-purpose input/output 32
	COMP3H	O	Comparator COMP3H result output
	PWM4A	O	PWM4 output A
	PWMSYNCO	O	PWMSYNCO signal output for monitoring
	SIO1_6	I/O	SIO1 input/output 6
51	GPIO33	I/O	General-purpose input/output 33
	COMP3L	O	Comparator COMP3L result output
	PWM5A	O	PWM5 output A
	PWM4B	O	PWM4 output B
	PWMSOC <sup>(2)</sup>	O	PWM SOC signal output for monitoring
	SIO1_7	I/O	SIO1 input/output 7
52	GPIO34	I/O	General-purpose input/output 34
	COMP4H	O	Comparator COMP4H result output
	PWM0A	O	PWM0 output A
	PWM6A	O	PWM6 output A
	PWM5A	O	PWM5 output A
	SIO1_8	I/O	SIO1 input/output 8
53	GPIO35	I/O	General-purpose input/output 35
	COMP4L	O	Comparator COMP4L result output
	PWM0B	O	PWM0 output B
	PWM4B	O	PWM4 output B
	PWM5B	O	PWM5 output B

Pin	Signal	Type <sup>(1)</sup>	Description
	SIO1_9	I/O	SIO1 input/output 9
54	GPIO36	I/O	General-purpose input/output 36
	COMP5H	O	Comparator COMP5H result output
	PWM7A	O	PWM7 output A
	PWM5B	O	PWM5 output B
	PWM6A	O	PWM6 output A
	SIO1_10	I/O	SIO1 input/output 10
55	GPIO37	I/O	General-purpose input/output 37
	COMP5L	O	Comparator COMP5L result output
	PWM7B	O	PWM7 output B
	PWM6B	O	PWM6 output B
	SIO1_11	I/O	SIO1 input/output 11
56	DVDD	S	Digital power, add 0.1uF bypass ceramic cap to DVSS
57	DVSS	S	Digital ground
58	GPIO38	I/O	General-purpose input/output 38
	SPI_SCLK	I/O	SPI clock input/output
	UART_TXD	O	UART transmit data
	UART_RXD	I	UART receive data
	PWMSOCA	O	PWM SOCA signal output for monitoring
	SIO1_12	I/O	SIO1 input/output 12
59	GPIO39	I/O	General-purpose input/output 39
	SPI_SFRM	I/O	SPI frame signal
	UART_RXD	I	UART receive data
	UART_TXD	O	UART transmit data
	PWMSOCB	O	PWM SOCB signal output for monitoring
	SIO1_13	I/O	SIO1 input/output 13
60	GPIO40	I/O	General-purpose input/output 40
	SPI_MOSI	I/O	SPI master output, slave input
	SPI_MISO	I/O	SPI master input, slave output
	I2C_SCL	I/O	I <sup>2</sup> C clock
	PWMSOCC	O	PWM SOCC signal output for monitoring

Pin	Signal	Type <sup>(1)</sup>	Description
	SIO1_14	I/O	SIO1 input/output 14
61	GPIO41	I/O	General-purpose input/output 41
	SPI_MISO	I/O	SPI master input, slave output
	SPI_MOSI	I/O	SPI master output, slave input
	I2C_SDA	I/O	I <sup>2</sup> C data
	PWMSYNCO	O	PWMSYNCO signal output for monitoring
	SIO1_15	I/O	SIO1 input/output 15
62	GPIO42	I/O	General-purpose input/output 42
	I2C_SCL	I/O	I <sup>2</sup> C clock
	COMP6H	O	Comparator COMP6H result output
	SPI_SCLK	I/O	SPI clock input/output
	SIO1_16	I/O	SIO1 input/output 16
63	GPIO43	I/O	General-purpose input/output 43
	I2C_SDA	I/O	I <sup>2</sup> C data
	COMP6L	O	Comparator COMP6L result output
	SPI_SFRM	I/O	SPI frame signal
	SIO1_17	I/O	SIO1 input/output 17
64	GPIO44	I/O	General-purpose input/output 44
	UART_TXD	O	UART transmit data
	UART_RXD	I	UART receive data
	COMP7H	O	Comparator COMP7H result output
	SPI_MOSI	I/O	SPI master output, slave input
	SPI_MISO	I/O	SPI master input, slave output
	SIO2_0	I/O	SIO2 input/output 0
65	GPIO45	I/O	General-purpose input/output 45
	UART_RXD	I	UART receive data
	UART_TXD	O	UART transmit data
	COMP7L	O	Comparator COMP7L result output
	SPI_MISO	I/O	SPI master input, slave output
	SPI_MOSI	I/O	SPI master output, slave input
	SIO2_1	I/O	SIO2 input/output 1

Pin	Signal	Type <sup>(1)</sup>	Description
66	GPIO46	I/O	General-purpose input/output 46
	SIO2_2	I/O	SIO2 input/output 2
67	BOOT (GPIO47)	I/O	Boot pin (General-purpose input/output 47)
	SIO2_3	I/O	SIO2 input/output 3
68	XRSTn	I	Device reset pin, reset the device when low
69	TRSTn	I	JTAG reset pin, reset the JTAG when low
70	GPIO48	I/O	General-purpose input/output 48
	TCK/SWCK	I	JTAG clock or SWD clock
	COMP0H	O	Comparator COMP0H result output
	COMP3H	O	Comparator COMP3H result output
	SIO2_4	I/O	SIO2 input/output 4
	<b>Note: when TRSTn is HIGH, this pin always works as TCK/SWCK and can't be configured as other functions.</b>		
71	GPIO49	I/O	General-purpose input/output 49
	TMS/SWD	I/O	JTAG mode select or SWD data
	COMP0L	O	Comparator COMP0L result output
	COMP3L	O	Comparator COMP3L result output
	SIO2_5	I/O	SIO2 input/output 5
	<b>Note: when TRSTn is HIGH, this pin always works as TMS/SWD and can't be configured as other functions.</b>		
72	GPIO50	I/O	General-purpose input/output 50
	TDI	I	JTAG data input
	SWCK(CAU)	I	SWD clock for CAU
	COMP1H	O	Comparator COMP1H result output
	COMP4H	O	Comparator COMP4H result output
	SIO2_6	I/O	SIO2 input/output 6
	<b>Note: when TRSTn is HIGH, this pin always works as TDI or SWCK(CAU) and can't be configured as other functions.</b>		
73	GPIO51	I/O	General-purpose input/output 51
	TDO	O	JTAG data output
	SWD(CAU)	I/O	SWD data for CAU
	COMP1L	O	Comparator COMP1L result output

Pin	Signal	Type <sup>(1)</sup>	Description
	COMP4L	O	Comparator COMP4L result output
	SIO2_7	I/O	SIO2 input/output 7
	<b>Note: when TRSTn is HIGH, this pin always works as TDO or SWD(CAU) and can't be configured as other functions.</b>		
74	GPIO52	I/O	General-purpose input/output 52
	PWM0A	O	PWM0 output A
	COMP2H	O	Comparator COMP2H result output
	COMP5H	O	Comparator COMP5H result output
	SIO2_8	I/O	SIO2 input/output 8
75	GPIO53	I/O	General-purpose input/output 53
	PWM0B	O	PWM0 output B
	COMP2L	O	Comparator COMP2L result output
	COMP5L	O	Comparator COMP5L result output
	SIO2_9	I/O	SIO2 input/output 9
76	GPIO54	I/O	General-purpose input/output 54
	PWM7A	O	PWM7 output A
	PWM4A	O	PWM4 output A
	SIO2_10	I/O	SIO2 input/output 10
77	GPIO55	I/O	General-purpose input/output 55
	PWM7B	O	PWM7 output B
	PWM5A	O	PWM5 output A
	PWM4B	O	PWM4 output B
	SIO2_11	I/O	SIO2 input/output 11
78	DVDD	S	Digital power, add 0.1uF bypass ceramic cap to DVSS
79	VCAP12	S	1.2V power, add 0.1uF bypass ceramic cap to DVSS
80	DVSS	S	Digital ground

[1] I = digital input, O = digital output, AI = analog input, AO = analog out, S = supply.

[2] PWMSOC signal is logic OR of PWMSOCA, PWMSOCB and PWMSOCC signal.

[3] All GPIO pins can be configured as ECAP input or output.

### 3.2 LQFP64

Figure 3-2: SPC1198 LQFP64 pinout

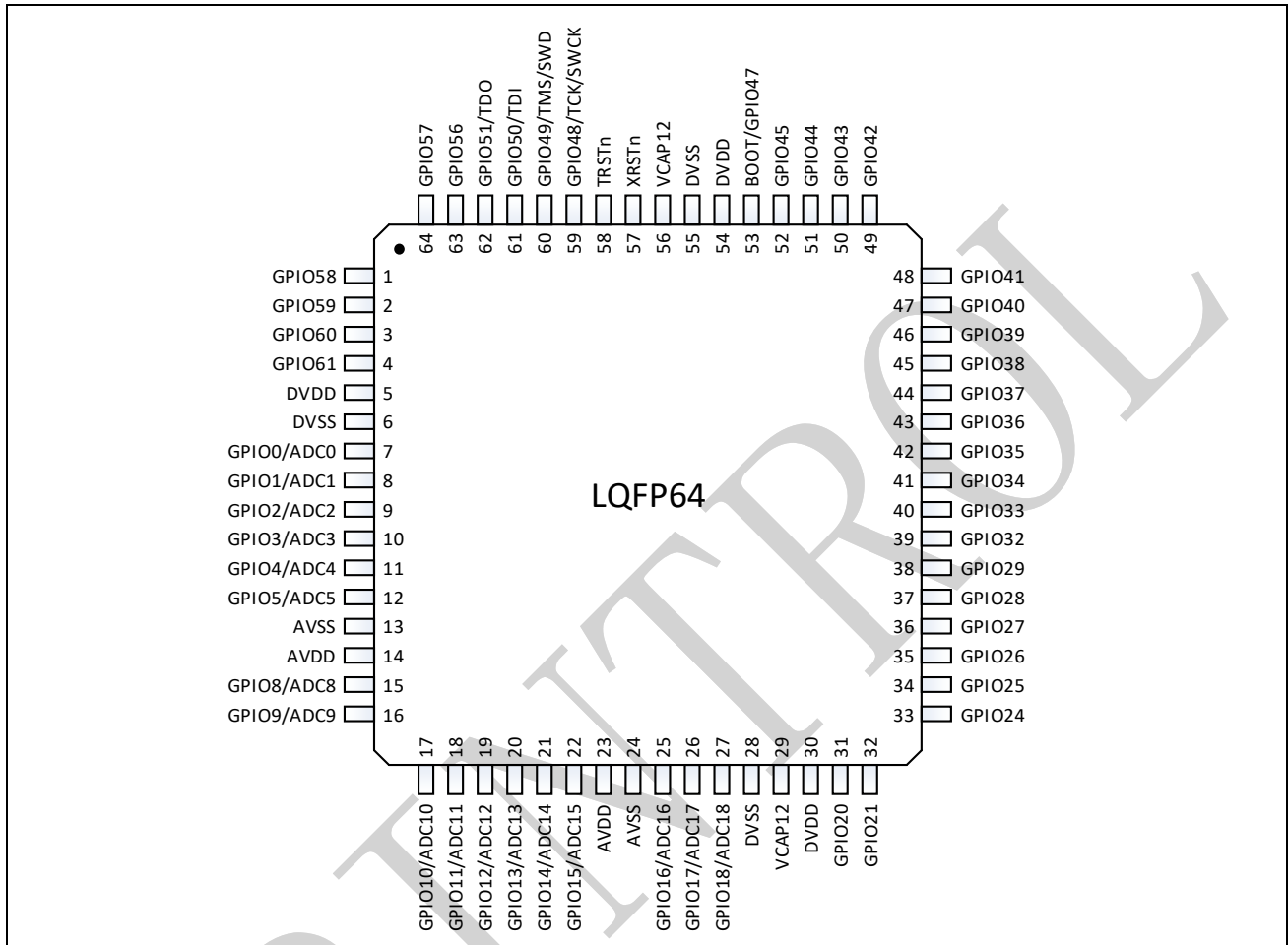

- [1] The figure above shows the package top view.
- [2] **Note:** there is no need to connect the two VCAP12 pins on the PCB boards.
- [3] **Note:** when TRSTn is HIGH, GPIO48 ~ GPIO51 pins work as Debug interface and can't be configured as other functions.

Table 3-2: SPC1198 LQFP64 pin definitions

Pin	Signal	Type <sup>(1)</sup>	Description
1	GPIO58	I/O	General-purpose input/output 58
	PWM6A	O	PWM6 output A
	PWM5A	O	PWM5 output A
	SIO2_14	I/O	SIO2 input/output 14
2	GPIO59	I/O	General-purpose input/output 59
	PWM4B	O	PWM4 output B
	PWM5B	O	PWM5 output B
	SIO2_15	I/O	SIO2 input/output 15

Pin	Signal	Type <sup>(1)</sup>	Description
3	GPIO60	I/O	General-purpose input/output 60
	PWM5B	O	PWM5 output B
	PWM6A	O	PWM6 output A
	SIO2_16	I/O	SIO2 input/output 16
4	GPIO61	I/O	General-purpose input/output 61
	PWM6B	O	PWM6 output B
	SIO2_17	I/O	SIO2 input/output 17
5	DVDD	S	Digital power, add 0.1uF bypass ceramic cap to DVSS
6	DVSS	S	Digital ground
7	GPIO0	I/O	General-purpose input/output 0
	ADC0	AI	ADC channel 0 input
	COMP0H	O	Comparator COMP0H result output
	SIO0_0	I/O	SIO0 input/output 0
8	GPIO1	I/O	General-purpose input/output 1
	ADC1	AI	ADC channel 1 input
	COMP0L	O	Comparator COMP0L result output
	SIO0_1	I/O	SIO0 input/output 1
9	GPIO2	I/O	General-purpose input/output 2
	ADC2	AI	ADC channel 2 input
	COMP1H	O	Comparator COMP1H result output
	SIO0_2	I/O	SIO0 input/output 2
10	GPIO3	I/O	General-purpose input/output 3
	ADC3	AI	ADC channel 3 input
	COMP1L	O	Comparator COMP1L result output
	SIO0_3	I/O	SIO0 input/output 3
11	GPIO4	I/O	General-purpose input/output 4
	ADC4	AI	ADC channel 4 input
	COMP2H	O	Comparator COMP2H result output
	SIO0_4	I/O	SIO0 input/output 4
12	GPIO5	I/O	General-purpose input/output 5
	ADC5	AI	ADC channel 5 input



Pin	Signal	Type <sup>(1)</sup>	Description
	COMP2L	O	Comparator COMP2L result output
	SIO0_5	I/O	SIO0 input/output 5
13	AVSS	S	Analog ground
14	AVDD	S	Analog power, <b>add 4.7uF and 0.1uF bypass ceramic cap to AVSS</b>
15	GPIO8	I/O	General-purpose input/output 8
	ADC8	AI	ADC channel 8 input
	SIO0_8	I/O	SIO0 input/output 8
16	GPIO9	I/O	General-purpose input/output 9
	ADC9	AI	ADC channel 9 input
	SIO0_9	I/O	SIO0 input/output 9
17	GPIO10	I/O	General-purpose input/output 10
	ADC10	AI	ADC channel 10 input
	COMP3H	O	Comparator COMP3H result output
	SIO0_10	I/O	SIO0 input/output 10
18	GPIO11	I/O	General-purpose input/output 11
	ADC11	AI	ADC channel 11 input
	COMP3L	O	Comparator COMP3L result output
	DCLK	O	Clock output from CLKDET module for monitoring
	SIO0_11	I/O	SIO0 input/output 11
19	GPIO12	I/O	General-purpose input/output 12
	ADC12	AI	ADC channel 12 input
	COMP4H	O	Comparator COMP4H result output
	SIO0_12	I/O	SIO0 input/output 12
20	GPIO13	I/O	General-purpose input/output 13
	ADC13	AI	ADC channel 13 input
	COMP4L	O	Comparator COMP4L result output
	SIO0_13	I/O	SIO0 input/output 13
21	GPIO14	I/O	General-purpose input/output 14
	ADC14	AI	ADC channel 14 input
	COMP5H	O	Comparator COMP5H result output

Pin	Signal	Type <sup>(1)</sup>	Description
	SIO0_14	I/O	SIO0 input/output 14
22	GPIO15	I/O	General-purpose input/output 15
	ADC15	AI	ADC channel 15 input
	COMP5L	O	Comparator COMP5L result output
	SIO0_15	I/O	SIO0 input/output 15
23	AVDD	S	Analog power, <b>add 4.7uF and 0.1uF bypass ceramic cap to AVSS</b>
24	AVSS	S	Analog ground
25	GPIO16	I/O	General-purpose input/output 16
	ADC16	AI	ADC channel 16 input
	COMP6H	O	Comparator COMP6H result output
	SIO0_16	I/O	SIO0 input/output 16
26	GPIO17	I/O	General-purpose input/output 17
	ADC17	AI	ADC channel 17 input
	COMP6L	O	Comparator COMP6L result output
	SIO0_17	I/O	SIO0 input/output 17
27	GPIO18	I/O	General-purpose input/output 18
	ADC18	AI	ADC channel 18 input
	COMP7H	O	Output of comparator 7 of high-voltage
	SIO0_0	I/O	SIO0 input/output 0
28	DVSS	S	Digital ground
29	VCAP12	S	1.2V power, add 2.2uF bypass ceramic cap to DVSS
30	DVDD	S	Digital power, add 4.7uF and 0.1uF ceramic cap to DVSS
31	GPIO20	I/O	General-purpose input/output 20
	XIN	AI	External oscillator input
	SPI_SCLK	I/O	SPI clock input/output
	I2C_SCL	I/O	I <sup>2</sup> C clock
	UART_TXD	O	UART transmit data
	PWMSYNCO	O	PWMSYNCO signal output for monitoring
	SIO0_2	I/O	SIO0 input/output 2
32	GPIO21	I/O	General-purpose input/output 21

Pin	Signal	Type <sup>(1)</sup>	Description
	XIO	AI/O	External oscillator input or output
	SPI_SFRM	I/O	SPI frame signal
	I2C_SDA	I/O	I <sup>2</sup> C data
	UART_RXD	I	UART receive data
	PWMSOC <sup>(2)</sup>	O	PWM SOC signal output for monitoring
	SIO0_3	I/O	SIO0 input/output 3
33	GPIO24	I/O	General-purpose input/output 24
	COMP0H	O	Comparator COMP0H result output
	PWM1A	O	PWM1 output A
	SIO0_6	I/O	SIO0 input/output 6
34	GPIO25	I/O	General-purpose input/output 25
	COMP0L	O	Comparator COMP0L result output
	PWM2A	O	PWM2 output A
	PWM1B	O	PWM1 output B
	SIO0_7	I/O	SIO0 input/output 7
35	GPIO26	I/O	General-purpose input/output 26
	COMP1H	O	Comparator COMP1H result output
	PWM3A	O	PWM3 output A
	PWM2A	O	PWM2 output A
	SIO1_0	I/O	SIO1 input/output 0
36	GPIO27	I/O	General-purpose input/output 27
	COMP1L	O	Comparator COMP1L result output
	PWM1B	O	PWM1 output B
	PWM2B	O	PWM2 output B
	SIO1_1	I/O	SIO1 input/output 1
37	GPIO28	I/O	General-purpose input/output 28
	COMP2H	O	Comparator COMP2H result output
	PWM2B	O	PWM2 output B
	PWM3A	O	PWM3 output A
	SIO1_2	I/O	SIO1 input/output 2
38	GPIO29	I/O	General-purpose input/output 29

Pin	Signal	Type <sup>(1)</sup>	Description
	COMP2L	O	Comparator COMP2L result output
	PWM3B	O	PWM3 output B
	SIO1_3	I/O	SIO1 input/output 3
39	GPIO32	I/O	General-purpose input/output 32
	COMP3H	O	Comparator COMP3H result output
	PWM4A	O	PWM4 output A
	PWMSYNCO	O	PWMSYNCO signal output for monitoring
	SIO1_6	I/O	SIO1 input/output 6
40	GPIO33	I/O	General-purpose input/output 33
	COMP3L	O	Comparator COMP3L result output
	PWM5A	O	PWM5 output A
	PWM4B	O	PWM4 output B
	PWMSOC <sup>(2)</sup>	O	PWM SOC signal output for monitoring
	SIO1_7	I/O	SIO1 input/output 7
41	GPIO34	I/O	General-purpose input/output 34
	COMP4H	O	Comparator COMP4H result output
	PWM0A	O	PWM0 output A
	PWM6A	O	PWM6 output A
	PWM5A	O	PWM5 output A
	SIO1_8	I/O	SIO1 input/output 8
42	GPIO35	I/O	General-purpose input/output 35
	COMP4L	O	Comparator COMP4L result output
	PWM0B	O	PWM0 output B
	PWM4B	O	PWM4 output B
	PWM5B	O	PWM5 output B
	SIO1_9	I/O	SIO1 input/output 9
43	GPIO36	I/O	General-purpose input/output 36
	COMP5H	O	Comparator COMP5H result output
	PWM7A	O	PWM7 output A
	PWM5B	O	PWM5 output B
	PWM6A	O	PWM6 output A

Pin	Signal	Type <sup>(1)</sup>	Description
	SIO1_10	I/O	SIO1 input/output 10
44	GPIO37	I/O	General-purpose input/output 37
	COMP5L	O	Comparator COMP5L result output
	PWM7B	O	PWM7 output B
	PWM6B	O	PWM6 output B
	SIO1_11	I/O	SIO1 input/output 11
45	GPIO38	I/O	General-purpose input/output 38
	SPI_SCLK	I/O	SPI clock input/output
	UART_TXD	O	UART transmit data
	UART_RXD	I	UART receive data
	PWMSOCA	O	PWM SOCA signal output for monitoring
	SIO1_12	I/O	SIO1 input/output 12
46	GPIO39	I/O	General-purpose input/output 39
	SPI_SFRM	I/O	SPI frame signal
	UART_RXD	I	UART receive data
	UART_TXD	O	UART transmit data
	PWMSOCB	O	PWM SOCB signal output for monitoring
	SIO1_13	I/O	SIO1 input/output 13
47	GPIO40	I/O	General-purpose input/output 40
	SPI_MOSI	I/O	SPI master output, slave input
	SPI_MISO	I/O	SPI master input, slave output
	I2C_SCL	I/O	I <sup>2</sup> C clock
	PWMSOCC	O	PWM SOCC signal output for monitoring
	SIO1_14	I/O	SIO1 input/output 14
48	GPIO41	I/O	General-purpose input/output 41
	SPI_MISO	I/O	SPI master input, slave output
	SPI_MOSI	I/O	SPI master output, slave input
	I2C_SDA	I/O	I <sup>2</sup> C data
	PWMSYNCO	O	PWMSYNCO signal output for monitoring
	SIO1_15	I/O	SIO1 input/output 15
49	GPIO42	I/O	General-purpose input/output 42

Pin	Signal	Type <sup>(1)</sup>	Description
	I2C_SCL	I/O	I <sup>2</sup> C clock
	COMP6H	O	Comparator COMP6H result output
	SPI_SCLK	I/O	SPI clock input/output
	SIO1_16	I/O	SIO1 input/output 16
50	GPIO43	I/O	General-purpose input/output 43
	I2C_SDA	I/O	I <sup>2</sup> C data
	COMP6L	O	Comparator COMP6L result output
	SPI_SFRM	I/O	SPI frame signal
	SIO1_17	I/O	SIO1 input/output 17
51	GPIO44	I/O	General-purpose input/output 44
	UART_TXD	O	UART transmit data
	UART_RXD	I	UART receive data
	COMP7H	O	Comparator COMP7H result output
	SPI_MOSI	I/O	SPI master output, slave input
	SPI_MISO	I/O	SPI master input, slave output
	SIO2_0	I/O	SIO2 input/output 0
52	GPIO45	I/O	General-purpose input/output 45
	UART_RXD	I	UART receive data
	UART_TXD	O	UART transmit data
	COMP7L	O	Comparator COMP7L result output
	SPI_MISO	I/O	SPI master input, slave output
	SPI_MOSI	I/O	SPI master output, slave input
	SIO2_1	I/O	SIO2 input/output 1
53	BOOT (GPIO47)	I/O	Boot pin (General-purpose input/output 47)
	SIO2_3	I/O	SIO2 input/output 3
54	DVDD	S	Digital power, add 0.1uF bypass ceramic cap to DVSS
55	DVSS	S	Digital ground
56	VCAP12	S	1.2V power, add 0.1uF bypass ceramic cap to DVSS
57	XRSTn	I	Device reset pin, reset the device when low
58	TRSTn	I	JTAG reset pin, reset the JTAG when low
59	GPIO48	I/O	General-purpose input/output 48

Pin	Signal	Type <sup>(1)</sup>	Description
	TCK/SWCK	I	JTAG clock or SWD clock
	COMP0H	O	Comparator COMP0H result output
	COMP3H	O	Comparator COMP3H result output
	SIO2_4	I/O	SIO2 input/output 4
	<b>Note: when TRSTn is HIGH, this pin always works as TCK/SWCK and can't be configured as other functions.</b>		
60	GPIO49	I/O	General-purpose input/output 49
	TMS/SWD	I/O	JTAG mode select or SWD data
	COMP0L	O	Comparator COMP0L result output
	COMP3L	O	Comparator COMP3L result output
	SIO2_5	I/O	SIO2 input/output 5
<b>Note: when TRSTn is HIGH, this pin always works as TMS/SWD and can't be configured as other functions.</b>			
61	GPIO50	I/O	General-purpose input/output 50
	TDI	I	JTAG data input
	SWCK(CAU)	I	SWD clock for CAU
	COMP1H	O	Comparator COMP1H result output
	COMP4H	O	Comparator COMP4H result output
	SIO2_6	I/O	SIO2 input/output 6
<b>Note: when TRSTn is HIGH, this pin always works as TDI or SWCK(CAU) and can't be configured as other functions.</b>			
62	GPIO51	I/O	General-purpose input/output 51
	TDO	O	JTAG data output
	SWD(CAU)	I/O	SWD data for CAU
	COMP1L	O	Comparator COMP1L result output
	COMP4L	O	Comparator COMP4L result output
	SIO2_7	I/O	SIO2 input/output 7
<b>Note: when TRSTn is HIGH, this pin always works as TDO or SWD(CAU) and can't be configured as other functions.</b>			
63	GPIO56	I/O	General-purpose input/output 56
	PWM4A	O	PWM4 output A
	SIO2_12	I/O	SIO2 input/output 12

Pin	Signal	Type <sup>(1)</sup>	Description
64	GPIO57	I/O	General-purpose input/output 57
	PWM5A	O	PWM5 output A
	PWM4B	O	PWM4 output B
	SIO2_13	I/O	SIO2 input/output 13

[1] I = digital input, O = digital output, AI = analog input, AO = analog out, S = supply.

[2] PWMSOC signal is logic OR of PWMSOCA, PWMSOCB and PWMSOCC signal.

[3] All GPIO pins can be configured as ECAP input or output.

SPINTROL



### 3.3 LQFP52

Figure 3-3: SPC1198 LQFP52 pinout

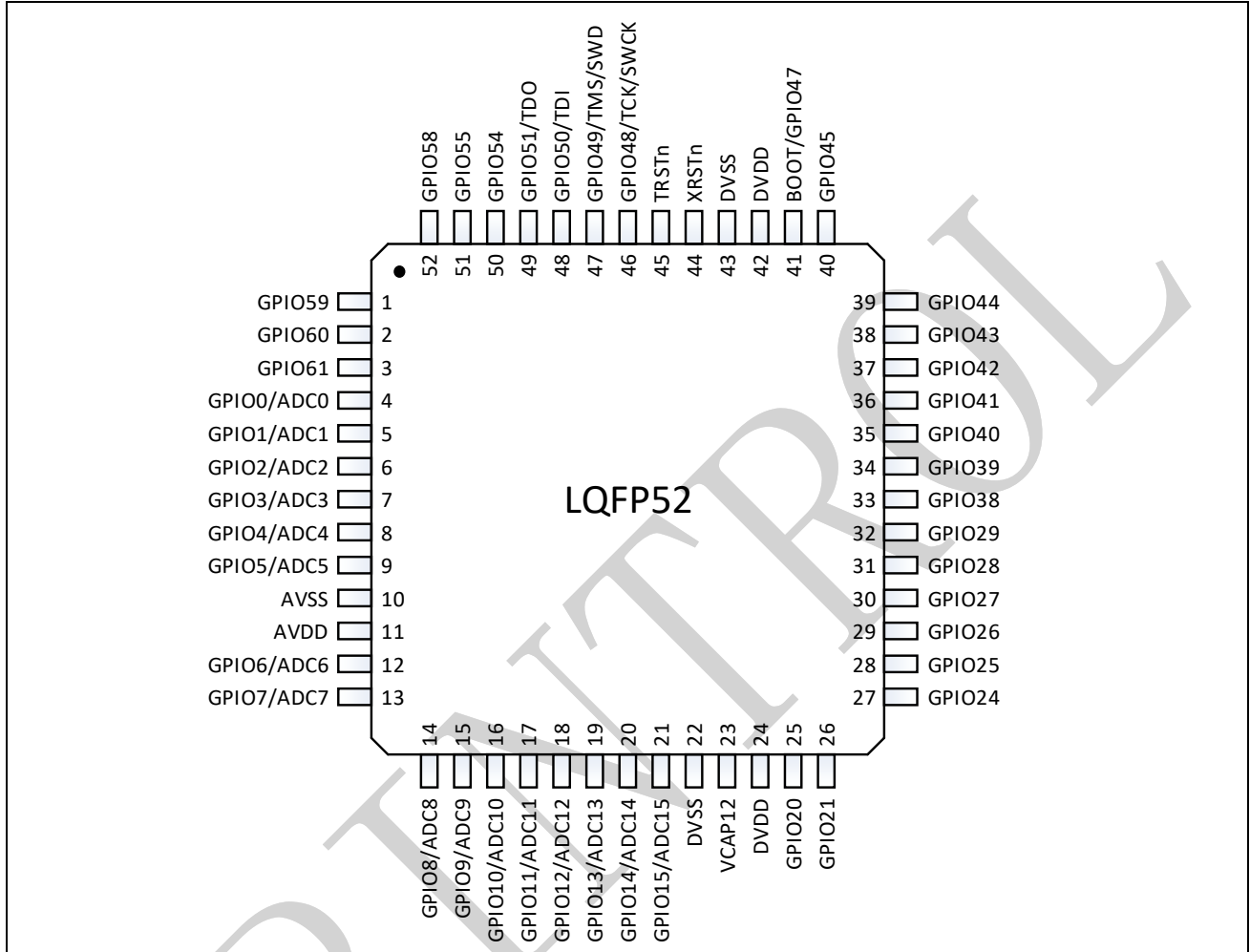

- [1] The figure above shows the package top view.
- [2] **Note:** there is no need to connect the two VCAP12 pins on the PCB boards.
- [3] **Note:** when TRSTn is HIGH, GPIO48 ~ GPIO51 pins work as Debug interface and can't be configured as other functions.

Table 3-3: SPC1198 LQFP52 pin definitions

Pin	Signal	Type <sup>(1)</sup>	Description
1	GPIO59	I/O	General-purpose input/output 59
	PWM4B	O	PWM4 output B
	PWM5B	O	PWM5 output B
2	SIO2_15	I/O	SIO2 input/output 15
	GPIO60	I/O	General-purpose input/output 60
	PWM5B	O	PWM5 output B
2	PWM6A	O	PWM6 output A

Pin	Signal	Type <sup>(1)</sup>	Description
	SIO2_16	I/O	SIO2 input/output 16
3	GPIO61	I/O	General-purpose input/output 61
	PWM6B	O	PWM6 output B
	SIO2_17	I/O	SIO2 input/output 17
4	GPIO0	I/O	General-purpose input/output 0
	ADC0	AI	ADC channel 0 input
	COMP0H	O	Comparator COMP0H result output
	SIO0_0	I/O	SIO0 input/output 0
5	GPIO1	I/O	General-purpose input/output 1
	ADC1	AI	ADC channel 1 input
	COMP0L	O	Comparator COMP0L result output
	SIO0_1	I/O	SIO0 input/output 1
6	GPIO2	I/O	General-purpose input/output 2
	ADC2	AI	ADC channel 2 input
	COMP1H	O	Comparator COMP1H result output
	SIO0_2	I/O	SIO0 input/output 2
7	GPIO3	I/O	General-purpose input/output 3
	ADC3	AI	ADC channel 3 input
	COMP1L	O	Comparator COMP1L result output
	SIO0_3	I/O	SIO0 input/output 3
8	GPIO4	I/O	General-purpose input/output 4
	ADC4	AI	ADC channel 4 input
	COMP2H	O	Comparator COMP2H result output
	SIO0_4	I/O	SIO0 input/output 4
9	GPIO5	I/O	General-purpose input/output 5
	ADC5	AI	ADC channel 5 input
	COMP2L	O	Comparator COMP2L result output
	SIO0_5	I/O	SIO0 input/output 5
10	AVSS	S	Analog ground
11	AVDD	S	Analog power, add 4.7uF and 0.1uF bypass ceramic cap to AVSS

Pin	Signal	Type <sup>(1)</sup>	Description
12	GPIO6	I/O	General-purpose input/output 6
	ADC6	AI	ADC channel 6 input
	SIO0_6	I/O	SIO0 input/output 6
13	GPIO7	I/O	General-purpose input/output 7
	ADC7	AI	ADC channel 7 input
	SIO0_7	I/O	SIO0 input/output 7
14	GPIO8	I/O	General-purpose input/output 8
	ADC8	AI	ADC channel 8 input
	SIO0_8	I/O	SIO0 input/output 8
15	GPIO9	I/O	General-purpose input/output 9
	ADC9	AI	ADC channel 9 input
	SIO0_9	I/O	SIO0 input/output 9
16	GPIO10	I/O	General-purpose input/output 10
	ADC10	AI	ADC channel 10 input
	COMP3H	O	Comparator COMP3H result output
	SIO0_10	I/O	SIO0 input/output 10
17	GPIO11	I/O	General-purpose input/output 11
	ADC11	AI	ADC channel 11 input
	COMP3L	O	Comparator COMP3L result output
	DCLK	O	Clock output from CLKDET module for monitoring
	SIO0_11	I/O	SIO0 input/output 11
18	GPIO12	I/O	General-purpose input/output 12
	ADC12	AI	ADC channel 12 input
	COMP4H	O	Comparator COMP4H result output
	SIO0_12	I/O	SIO0 input/output 12
19	GPIO13	I/O	General-purpose input/output 13
	ADC13	AI	ADC channel 13 input
	COMP4L	O	Comparator COMP4L result output
	SIO0_13	I/O	SIO0 input/output 13
20	GPIO14	I/O	General-purpose input/output 14
	ADC14	AI	ADC channel 14 input

Pin	Signal	Type <sup>(1)</sup>	Description
	COMP5H	O	Comparator COMP5H result output
	SIO0_14	I/O	SIO0 input/output 14
21	GPIO15	I/O	General-purpose input/output 15
	ADC15	AI	ADC channel 15 input
	COMP5L	O	Comparator COMP5L result output
	SIO0_15	I/O	SIO0 input/output 15
22	DVSS	S	Digital ground
23	VCAP12	S	1.2V power, add 4.7uF bypass ceramic cap to DVSS
24	DVDD	S	Digital power, add 4.7uF and 0.1uF ceramic cap to DVSS
25	GPIO20	I/O	General-purpose input/output 20
	XIN	AI	External oscillator input
	SPI_SCLK	I/O	SPI clock input/output
	I2C_SCL	I/O	I <sup>2</sup> C clock
	UART_TXD	O	UART transmit data
	PWMSYNCO	O	PWMSYNCO signal output for monitoring
	SIO0_2	I/O	SIO0 input/output 2
26	GPIO21	I/O	General-purpose input/output 21
	XIO	AI/O	External oscillator input or output
	SPI_SFRM	I/O	SPI frame signal
	I2C_SDA	I/O	I <sup>2</sup> C data
	UART_RXD	I	UART receive data
	PWMSOC <sup>(2)</sup>	O	PWM SOC signal output for monitoring
	SIO0_3	I/O	SIO0 input/output 3
27	GPIO24	I/O	General-purpose input/output 24
	COMP0H	O	Comparator COMP0H result output
	PWM1A	O	PWM1 output A
	SIO0_6	I/O	SIO0 input/output 6
28	GPIO25	I/O	General-purpose input/output 25
	COMP0L	O	Comparator COMP0L result output
	PWM2A	O	PWM2 output A
	PWM1B	O	PWM1 output B

Pin	Signal	Type <sup>(1)</sup>	Description
	SIO0_7	I/O	SIO0 input/output 7
29	GPIO26	I/O	General-purpose input/output 26
	COMP1H	O	Comparator COMP1H result output
	PWM3A	O	PWM3 output A
	PWM2A	O	PWM2 output A
	SIO1_0	I/O	SIO1 input/output 0
30	GPIO27	I/O	General-purpose input/output 27
	COMP1L	O	Comparator COMP1L result output
	PWM1B	O	PWM1 output B
	PWM2B	O	PWM2 output B
	SIO1_1	I/O	SIO1 input/output 1
31	GPIO28	I/O	General-purpose input/output 28
	COMP2H	O	Comparator COMP2H result output
	PWM2B	O	PWM2 output B
	PWM3A	O	PWM3 output A
	SIO1_2	I/O	SIO1 input/output 2
32	GPIO29	I/O	General-purpose input/output 29
	COMP2L	O	Comparator COMP2L result output
	PWM3B	O	PWM3 output B
	SIO1_3	I/O	SIO1 input/output 3
33	GPIO38	I/O	General-purpose input/output 38
	SPI_SCLK	I/O	SPI clock input/output
	UART_TXD	O	UART transmit data
	UART_RXD	I	UART receive data
	PWMSOCA	O	PWM SOCA signal output for monitoring
	SIO1_12	I/O	SIO1 input/output 12
34	GPIO39	I/O	General-purpose input/output 39
	SPI_SFRM	I/O	SPI frame signal
	UART_RXD	I	UART receive data
	UART_TXD	O	UART transmit data
	PWMSOCB	O	PWM SOCB signal output for monitoring

Pin	Signal	Type <sup>(1)</sup>	Description
	SIO1_13	I/O	SIO1 input/output 13
35	GPIO40	I/O	General-purpose input/output 40
	SPI_MOSI	I/O	SPI master output, slave input
	SPI_MISO	I/O	SPI master input, slave output
	I2C_SCL	I/O	I <sup>2</sup> C clock
	PWMSOCC	O	PWM SOCC signal output for monitoring
	SIO1_14	I/O	SIO1 input/output 14
36	GPIO41	I/O	General-purpose input/output 41
	SPI_MISO	I/O	SPI master input, slave output
	SPI_MOSI	I/O	SPI master output, slave input
	I2C_SDA	I/O	I <sup>2</sup> C data
	PWMSYNCO	O	PWMSYNCO signal output for monitoring
	SIO1_15	I/O	SIO1 input/output 15
37	GPIO42	I/O	General-purpose input/output 42
	I2C_SCL	I/O	I <sup>2</sup> C clock
	COMP6H	O	Comparator COMP6H result output
	SPI_SCLK	I/O	SPI clock input/output
	SIO1_16	I/O	SIO1 input/output 16
38	GPIO43	I/O	General-purpose input/output 43
	I2C_SDA	I/O	I <sup>2</sup> C data
	COMP6L	O	Comparator COMP6L result output
	SPI_SFRM	I/O	SPI frame signal
	SIO1_17	I/O	SIO1 input/output 17
39	GPIO44	I/O	General-purpose input/output 44
	UART_TXD	O	UART transmit data
	UART_RXD	I	UART receive data
	COMP7H	O	Comparator COMP7H result output
	SPI_MOSI	I/O	SPI master output, slave input
	SPI_MISO	I/O	SPI master input, slave output
	SIO2_0	I/O	SIO2 input/output 0
40	GPIO45	I/O	General-purpose input/output 45

Pin	Signal	Type <sup>(1)</sup>	Description
	UART_RXD	I	UART receive data
	UART_TXD	O	UART transmit data
	COMP7L	O	Comparator COMP7L result output
	SPI_MISO	I/O	SPI master input, slave output
	SPI_MOSI	I/O	SPI master output, slave input
	SIO2_1	I/O	SIO2 input/output 1
41	BOOT (GPIO47)	I/O	Boot pin (General-purpose input/output 47)
	SIO2_3	I/O	SIO2 input/output 3
42	DVDD	S	Digital power, add 0.1uF bypass ceramic cap to DVSS
43	DVSS	S	Digital ground
44	XRSTn	I	Device reset pin, reset the device when low
45	TRSTn	I	JTAG reset pin, reset the JTAG when low
46	GPIO48	I/O	General-purpose input/output 48
	TCK/SWCK	I	JTAG clock or SWD clock
	COMP0H	O	Comparator COMP0H result output
	COMP3H	O	Comparator COMP3H result output
	SIO2_4	I/O	SIO2 input/output 4
<b>Note: when TRSTn is HIGH, this pin always works as TCK/SWCK and can't be configured as other functions.</b>			
47	GPIO49	I/O	General-purpose input/output 49
	TMS/SWD	I/O	JTAG mode select or SWD data
	COMP0L	O	Comparator COMP0L result output
	COMP3L	O	Comparator COMP3L result output
	SIO2_5	I/O	SIO2 input/output 5
<b>Note: when TRSTn is HIGH, this pin always works as TMS/SWD and can't be configured as other functions.</b>			
48	GPIO50	I/O	General-purpose input/output 50
	TDI	I	JTAG data input
	SWCK(CAU)	I	SWD clock for CAU
	COMP1H	O	Comparator COMP1H result output
	COMP4H	O	Comparator COMP4H result output

Pin	Signal	Type <sup>(1)</sup>	Description
	SIO2_6	I/O	SIO2 input/output 6
	<b>Note: when TRSTn is HIGH, this pin always works as TDI or SWCK(CAU) and can't be configured as other functions.</b>		
49	GPIO51	I/O	General-purpose input/output 51
	TDO	O	JTAG data output
	SWD(CAU)	I/O	SWD data for CAU
	COMP1L	O	Comparator COMP1L result output
	COMP4L	O	Comparator COMP4L result output
	SIO2_7	I/O	SIO2 input/output 7
<b>Note: when TRSTn is HIGH, this pin always works as TDO or SWD(CAU) and can't be configured as other functions.</b>			
50	GPIO54	I/O	General-purpose input/output 54
	PWM7A	O	PWM7 output A
	PWM4A	O	PWM4 output A
	SIO2_10	I/O	SIO2 input/output 10
51	GPIO55	I/O	General-purpose input/output 55
	PWM7B	O	PWM7 output B
	PWM5A	O	PWM5 output A
	PWM4B	O	PWM4 output B
	SIO2_11	I/O	SIO2 input/output 11
52	GPIO58	I/O	General-purpose input/output 58
	PWM6A	O	PWM6 output A
	PWM5A	O	PWM5 output A
	SIO2_14	I/O	SIO2 input/output 14

[1] I = digital input, O = digital output, AI = analog input, AO = analog out, S = supply.

[2] PWMSOC signal is logic OR of PWMSOCA, PWMSOCB and PWMSOCC signal.

[3] All GPIO pins can be configured as ECAP input or output.



### 3.4 LQFP48

Figure 3-4: SPC1198 LQFP48 pinout

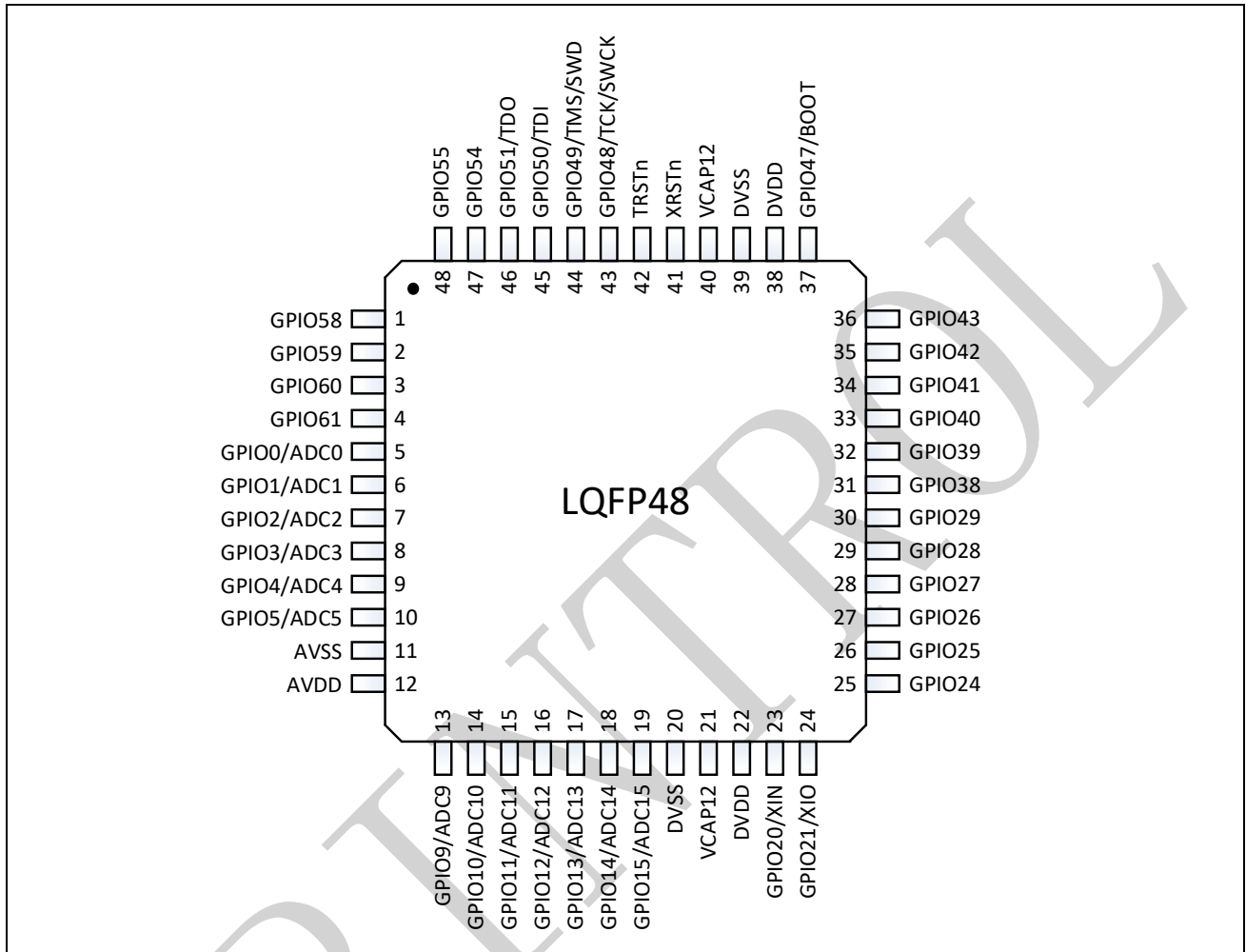

- [1] The above figure shows the package top view.
- [2] **Note:** there is no need to connect the two VCAP12 pins on the PCB boards.
- [3] **Note:** when TRSTn is HIGH, GPIO48 ~ GPIO51 pins work as Debug interface and can't be configured as other functions.

Table 3-4: SPC1198 LQFP48 pin definitions

Pin	Signal	Type <sup>(1)</sup>	Description
1	GPIO58	I/O	General-purpose input/output 58
	PWM6A	O	PWM6 output A
	PWM5A	O	PWM5 output A
	SIO2_14	I/O	SIO2 input/output 14
2	GPIO59	I/O	General-purpose input/output 59
	PWM4B	O	PWM4 output B
	PWM5B	O	PWM5 output B

Pin	Signal	Type <sup>(1)</sup>	Description
	SIO2_15	I/O	SIO2 input/output 15
3	GPIO60	I/O	General-purpose input/output 60
	PWM5B	O	PWM5 output B
	PWM6A	O	PWM6 output A
	SIO2_16	I/O	SIO2 input/output 16
4	GPIO61	I/O	General-purpose input/output 61
	PWM6B	O	PWM6 output B
	SIO2_17	I/O	SIO2 input/output 17
5	GPIO0	I/O	General-purpose input/output 0
	ADC0	AI	ADC channel 0 input
	COMP0H	O	Comparator COMP0H result output
	SIO0_0	I/O	SIO0 input/output 0
6	GPIO1	I/O	General-purpose input/output 1
	ADC1	AI	ADC channel 1 input
	COMP0L	O	Comparator COMP0L result output
	SIO0_1	I/O	SIO0 input/output 1
7	GPIO2	I/O	General-purpose input/output 2
	ADC2	AI	ADC channel 2 input
	COMP1H	O	Comparator COMP1H result output
	SIO0_2	I/O	SIO0 input/output 2
8	GPIO3	I/O	General-purpose input/output 3
	ADC3	AI	ADC channel 3 input
	COMP1L	O	Comparator COMP1L result output
	SIO0_3	I/O	SIO0 input/output 3
9	GPIO4	I/O	General-purpose input/output 4
	ADC4	AI	ADC channel 4 input
	COMP2H	O	Comparator COMP2H result output
	SIO0_4	I/O	SIO0 input/output 4
10	GPIO5	I/O	General-purpose input/output 5
	ADC5	AI	ADC channel 5 input
	COMP2L	O	Comparator COMP2L result output
	SIO0_5	I/O	SIO0 input/output 5
11	AVSS	S	Analog ground
12	AVDD	S	Analog power, <b>add 4.7uF and 0.1uF bypass ceramic cap to</b>

Pin	Signal	Type <sup>(1)</sup>	Description
			<b>AVSS</b>
13	GPIO9	I/O	General-purpose input/output 9
	ADC9	AI	ADC channel 9 input
	SIO0_9	I/O	SIO0 input/output 9
14	GPIO10	I/O	General-purpose input/output 10
	ADC10	AI	ADC channel 10 input
	COMP3H	O	Comparator COMP3H result output
	SIO0_10	I/O	SIO0 input/output 10
15	GPIO11	I/O	General-purpose input/output 11
	ADC11	AI	ADC channel 11 input
	COMP3L	O	Comparator COMP3L result output
	DCLK	O	Clock output from CLKDET module for monitoring
	SIO0_11	I/O	SIO0 input/output 11
16	GPIO12	I/O	General-purpose input/output 12
	ADC12	AI	ADC channel 12 input
	COMP4H	O	Comparator COMP4H result output
	SIO0_12	I/O	SIO0 input/output 12
17	GPIO13	I/O	General-purpose input/output 13
	ADC13	AI	ADC channel 13 input
	COMP4L	O	Comparator COMP4L result output
	SIO0_13	I/O	SIO0 input/output 13
18	GPIO14	I/O	General-purpose input/output 14
	ADC14	AI	ADC channel 14 input
	COMP5H	O	Comparator COMP5H result output
	SIO0_14	I/O	SIO0 input/output 14
19	GPIO15	I/O	General-purpose input/output 15
	ADC15	AI	ADC channel 15 input
	COMP5L	O	Comparator COMP5L result output
	SIO0_15	I/O	SIO0 input/output 15
20	DVSS	S	Digital ground
21	VCAP12	S	1.2V power, <b>add 2.2uF bypass ceramic cap to DVSS</b>
22	DVDD	S	Digital power, <b>add 4.7uF and 0.1uF ceramic cap to DVSS</b>
23	GPIO20	I/O	General-purpose input/output 20
	XIN	AI	External oscillator input

Pin	Signal	Type <sup>(1)</sup>	Description
	SPI_SCLK	I/O	SPI clock input/output
	I2C_SCL	I/O	I <sup>2</sup> C clock
	UART_TXD	O	UART transmit data
	PWMSYNCO	O	PWMSYNCO signal output for monitoring
	SIO0_2	I/O	SIO0 input/output 2
24	GPIO21	I/O	General-purpose input/output 21
	XIO	AI/O	External oscillator input or output
	SPI_SFRM	I/O	SPI frame signal
	I2C_SDA	I/O	I <sup>2</sup> C data
	UART_RXD	I	UART receive data
	PWMSOC <sup>(2)</sup>	O	PWM SOC signal output for monitoring
	SIO0_3	I/O	SIO0 input/output 3
25	GPIO24	I/O	General-purpose input/output 24
	COMP0H	O	Comparator COMP0H result output
	PWM1A	O	PWM1 output A
	SIO0_6	I/O	SIO0 input/output 6
26	GPIO25	I/O	General-purpose input/output 25
	COMP0L	O	Comparator COMP0L result output
	PWM2A	O	PWM2 output A
	PWM1B	O	PWM1 output B
	SIO0_7	I/O	SIO0 input/output 7
27	GPIO26	I/O	General-purpose input/output 26
	COMP1H	O	Comparator COMP1H result output
	PWM3A	O	PWM3 output A
	PWM2A	O	PWM2 output A
	SIO1_0	I/O	SIO1 input/output 0
28	GPIO27	I/O	General-purpose input/output 27
	COMP1L	O	Comparator COMP1L result output
	PWM1B	O	PWM1 output B
	PWM2B	O	PWM2 output B
	SIO1_1	I/O	SIO1 input/output 1
29	GPIO28	I/O	General-purpose input/output 28
	COMP2H	O	Comparator COMP2H result output
	PWM2B	O	PWM2 output B

Pin	Signal	Type <sup>(1)</sup>	Description
	PWM3A	O	PWM3 output A
	SIO1_2	I/O	SIO1 input/output 2
30	GPIO29	I/O	General-purpose input/output 29
	COMP2L	O	Comparator COMP2L result output
	PWM3B	O	PWM3 output B
	SIO1_3	I/O	SIO1 input/output 3
31	GPIO38	I/O	General-purpose input/output 38
	SPI_SCLK	I/O	SPI clock input/output
	UART_TXD	O	UART transmit data
	UART_RXD	I	UART receive data
	PWMSOCA	O	PWM SOCA signal output for monitoring
	SIO1_12	I/O	SIO1 input/output 12
32	GPIO39	I/O	General-purpose input/output 39
	SPI_SFRM	I/O	SPI frame signal
	UART_RXD	I	UART receive data
	UART_TXD	O	UART transmit data
	PWMSOCB	O	PWM SOCB signal output for monitoring
	SIO1_13	I/O	SIO1 input/output 13
33	GPIO40	I/O	General-purpose input/output 40
	SPI_MOSI	I/O	SPI master output, slave input
	SPI_MISO	I/O	SPI master input, slave output
	I2C_SCL	I/O	I <sup>2</sup> C clock
	PWMSOCC	O	PWM SOCC signal output for monitoring
	SIO1_14	I/O	SIO1 input/output 14
34	GPIO41	I/O	General-purpose input/output 41
	SPI_MISO	I/O	SPI master input, slave output
	SPI_MOSI	I/O	SPI master output, slave input
	I2C_SDA	I/O	I <sup>2</sup> C data
	PWMSYNCO	O	PWMSYNCO signal output for monitoring
	SIO1_15	I/O	SIO1 input/output 15
35	GPIO42	I/O	General-purpose input/output 42
	I2C_SCL	I/O	I <sup>2</sup> C clock
	COMP6H	O	Comparator COMP6H result output
	SPI_SCLK	I/O	SPI clock input/output

Pin	Signal	Type <sup>(1)</sup>	Description
	SIO1_16	I/O	SIO1 input/output 16
36	GPIO43	I/O	General-purpose input/output 43
	I2C_SDA	I/O	I <sup>2</sup> C data
	COMP6L	O	Comparator COMP6L result output
	SPI_SFRM	I/O	SPI frame signal
	SIO1_17	I/O	SIO1 input/output 17
37	BOOT (GPIO47)	I/O	Boot pin (General-purpose input/output 47)
	SIO2_3	I/O	SIO2 input/output 3
38	DVDD	S	Digital power, <b>add 0.1uF bypass ceramic cap to DVSS</b>
39	DVSS	S	Digital ground
40	VCAP12	S	1.2V power, <b>add 2.2uF bypass ceramic cap to DVSS</b>
41	XRSTn	I	Device reset pin, reset the device when low
42	TRSTn	I	JTAG reset pin, reset the JTAG when low
43	GPIO48	I/O	General-purpose input/output 48
	TCK/SWCK	I	JTAG clock or SWD clock
	COMP0H	O	Comparator COMP0H result output
	COMP3H	O	Comparator COMP3H result output
	SIO2_4	I/O	SIO2 input/output 4
44	GPIO49	I/O	General-purpose input/output 49
	TMS/SWD	I/O	JTAG mode select or SWD data
	COMP0L	O	Comparator COMP0L result output
	COMP3L	O	Comparator COMP3L result output
	SIO2_5	I/O	SIO2 input/output 5
45	GPIO50	I/O	General-purpose input/output 50
	TDI	I	JTAG data input
	SWCK(CAU)	I	SWD clock for CAU
	COMP1H	O	Comparator COMP1H result output
	COMP4H	O	Comparator COMP4H result output
	SIO2_6	I/O	SIO2 input/output 6

Pin	Signal	Type <sup>(1)</sup>	Description
46	GPIO51	I/O	General-purpose input/output 51
	TDO	O	JTAG data output
	SWD(CAU)	I/O	SWD data for CAU
	COMP1L	O	Comparator COMP1L result output
	COMP4L	O	Comparator COMP4L result output
	SIO2_7	I/O	SIO2 input/output 7
<b>Note: when TRSTn is HIGH, this pin always works as TDO or SWD(CAU) and can't be configured as other functions.</b>			
47	GPIO54	I/O	General-purpose input/output 54
	PWM7A	O	PWM7 output A
	PWM4A	O	PWM4 output A
	SIO2_10	I/O	SIO2 input/output 10
48	GPIO55	I/O	General-purpose input/output 55
	PWM7B	O	PWM7 output B
	PWM5A	O	PWM5 output A
	PWM4B	O	PWM4 output B
	SIO2_11	I/O	SIO2 input/output 11

[1] I = digital input, O = digital output, AI = analog input, AO = analog out, S = supply.

[2] PWMSOC signal is logic OR of PWMSOCA, PWMSOCB and PWMSOCC signal.

[3] All GPIO pins can be configured as ECAP input or output.

### 3.5 QFN52

Figure 3-5: SPC1198 QFN52 pinout

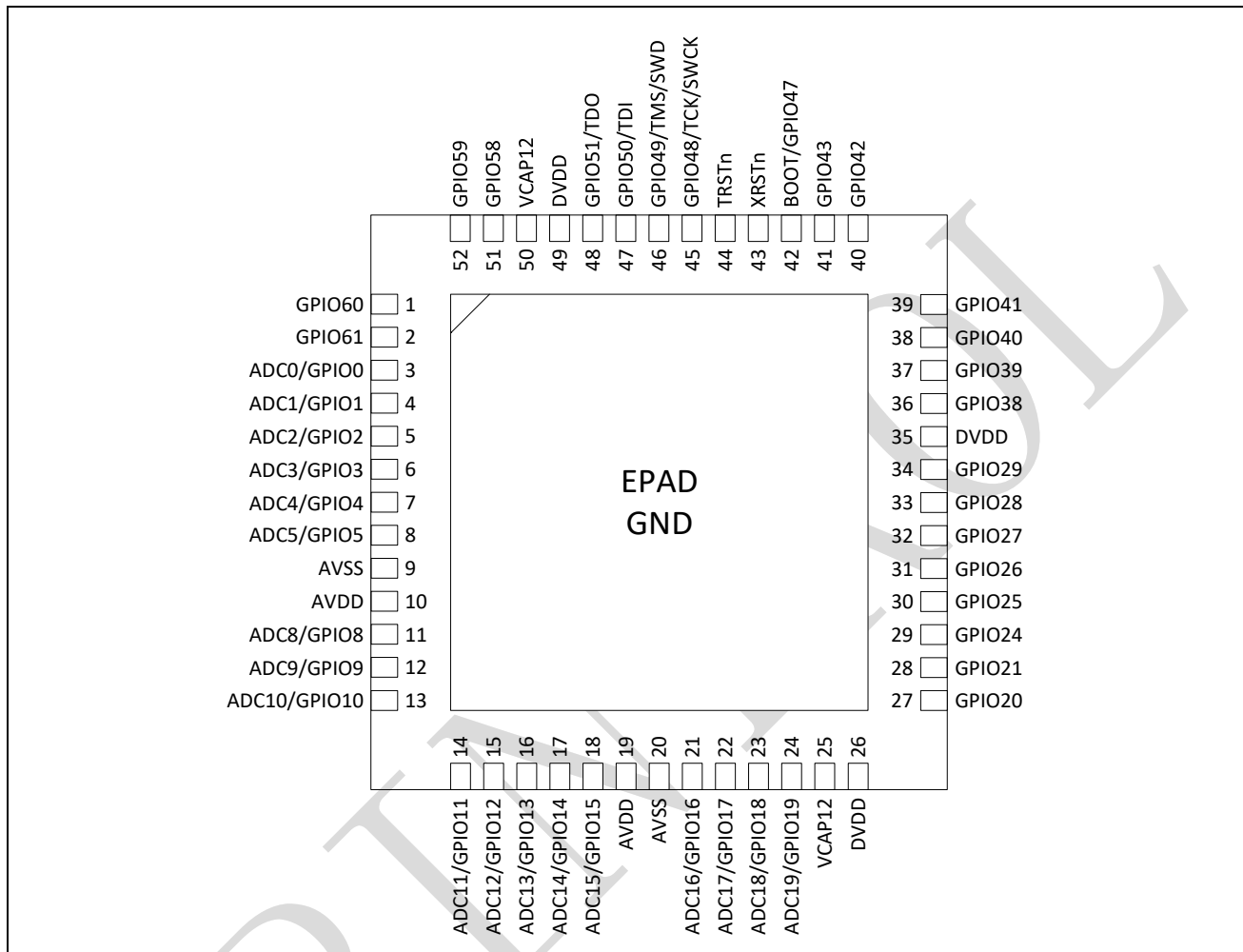

- [1] The above figure shows the package top view.
- [2] **Note:** there is no need to connect the two VCAP12 pins on the PCB boards.
- [3] **Note:** when TRSTn is HIGH, GPIO48 ~ GPIO51 pins work as Debug interface and can't be configured as other functions.

Table 3-5: SPC1198 QFN52 pin definitions

Pin	Signal	Type <sup>(1)</sup>	Description
1	GPIO60	I/O	General-purpose input/output 60
	PWM5B	O	PWM5 output B
	PWM6A	O	PWM6 output A
	SIO2_16	I/O	SIO2 input/output 16
2	GPIO61	I/O	General-purpose input/output 61
	PWM6B	O	PWM6 output B
	SIO2_17	I/O	SIO2 input/output 17



Pin	Signal	Type <sup>(1)</sup>	Description
3	GPIO0	I/O	General-purpose input/output 0
	ADC0	AI	ADC channel 0 input
	COMP0H	O	Comparator COMP0H result output
	SIO0_0	I/O	SIO0 input/output 0
4	GPIO1	I/O	General-purpose input/output 1
	ADC1	AI	ADC channel 1 input
	COMP0L	O	Comparator COMP0L result output
	SIO0_1	I/O	SIO0 input/output 1
5	GPIO2	I/O	General-purpose input/output 2
	ADC2	AI	ADC channel 2 input
	COMP1H	O	Comparator COMP1H result output
	SIO0_2	I/O	SIO0 input/output 2
6	GPIO3	I/O	General-purpose input/output 3
	ADC3	AI	ADC channel 3 input
	COMP1L	O	Comparator COMP1L result output
	SIO0_3	I/O	SIO0 input/output 3
7	GPIO4	I/O	General-purpose input/output 4
	ADC4	AI	ADC channel 4 input
	COMP2H	O	Comparator COMP2H result output
	SIO0_4	I/O	SIO0 input/output 4
8	GPIO5	I/O	General-purpose input/output 5
	ADC5	AI	ADC channel 5 input
	COMP2L	O	Comparator COMP2L result output
	SIO0_5	I/O	SIO0 input/output 5
9	AVSS	S	Analog ground
10	AVDD	S	Analog power, <b>add 4.7uF and 0.1uF bypass ceramic cap to AVSS</b>
11	GPIO8	I/O	General-purpose input/output 8
	ADC8	AI	ADC channel 8 input
	SIO0_8	I/O	SIO0 input/output 8
12	GPIO9	I/O	General-purpose input/output 9
	ADC9	AI	ADC channel 9 input
	SIO0_9	I/O	SIO0 input/output 9
13	GPIO10	I/O	General-purpose input/output 10

Pin	Signal	Type <sup>(1)</sup>	Description
	ADC10	AI	ADC channel 10 input
	COMP3H	O	Comparator COMP3H result output
	SIO0_10	I/O	SIO0 input/output 10
14	GPIO11	I/O	General-purpose input/output 11
	ADC11	AI	ADC channel 11 input
	COMP3L	O	Comparator COMP3L result output
	DCLK	O	Clock output from CLKDET module for monitoring
	SIO0_11	I/O	SIO0 input/output 11
15	GPIO12	I/O	General-purpose input/output 12
	ADC12	AI	ADC channel 12 input
	COMP4H	O	Comparator COMP4H result output
	SIO0_12	I/O	SIO0 input/output 12
16	GPIO13	I/O	General-purpose input/output 13
	ADC13	AI	ADC channel 13 input
	COMP4L	O	Comparator COMP4L result output
	SIO0_13	I/O	SIO0 input/output 13
17	GPIO14	I/O	General-purpose input/output 14
	ADC14	AI	ADC channel 14 input
	COMP5H	O	Comparator COMP5H result output
	SIO0_14	I/O	SIO0 input/output 14
18	GPIO15	I/O	General-purpose input/output 15
	ADC15	AI	ADC channel 15 input
	COMP5L	O	Comparator COMP5L result output
	SIO0_15	I/O	SIO0 input/output 15
19	AVDD	S	Analog power, <b>add 4.7uF and 0.1uF bypass ceramic cap to AVSS</b>
20	AVSS	S	Analog ground
21	GPIO16	I/O	General-purpose input/output 16
	ADC16	AI	ADC channel 16 input
	COMP6H	O	Comparator COMP6H result output
	SIO0_16	I/O	SIO0 input/output 16
22	GPIO17	I/O	General-purpose input/output 17
	ADC17	AI	ADC channel 17 input
	COMP6L	O	Comparator COMP6L result output

Pin	Signal	Type <sup>(1)</sup>	Description
	SIO0_17	I/O	SIO0 input/output 17
23	GPIO18	I/O	General-purpose input/output 18
	ADC18	AI	ADC channel 18 input
	COMP7H	O	Comparator COMP7H result output
	SIO0_0	I/O	SIO0 input/output 0
24	GPIO19	I/O	General-purpose input/output 19
	ADC19	AI	ADC channel 19 input
	COMP7L	O	Comparator COMP7L result output
	SIO0_1	I/O	SIO0 input/output 1
25	VCAP12	S	1.2V power, <b>add 2.2uF bypass ceramic cap to DVSS</b>
26	DVDD	S	Digital power, <b>add 4.7uF and 0.1uF ceramic cap to DVSS</b>
27	GPIO20	I/O	General-purpose input/output 20
	XIN	AI	External oscillator input
	SPI_SCLK	I/O	SPI clock input/output
	I2C_SCL	I/O	I <sup>2</sup> C clock
	UART_TXD	O	UART transmit data
	PWMSYNCO	O	PWMSYNCO signal output for monitoring
	SIO0_2	I/O	SIO0 input/output 2
28	GPIO21	I/O	General-purpose input/output 21
	XIO	AI/O	External oscillator input or output
	SPI_SFRM	I/O	SPI frame signal
	I2C_SDA	I/O	I <sup>2</sup> C data
	UART_RXD	I	UART receive data
	PWMSOC <sup>(2)</sup>	O	PWM SOC signal output for monitoring
	SIO0_3	I/O	SIO0 input/output 3
29	GPIO24	I/O	General-purpose input/output 24
	COMP0H	O	Comparator COMP0H result output
	PWM1A	O	PWM1 output A
	SIO0_6	I/O	SIO0 input/output 6
30	GPIO25	I/O	General-purpose input/output 25
	COMP0L	O	Comparator COMP0L result output
	PWM2A	O	PWM2 output A
	PWM1B	O	PWM1 output B
	SIO0_7	I/O	SIO0 input/output 7

Pin	Signal	Type <sup>(1)</sup>	Description
31	GPIO26	I/O	General-purpose input/output 26
	COMP1H	O	Comparator COMP1H result output
	PWM3A	O	PWM3 output A
	PWM2A	O	PWM2 output A
	SIO1_0	I/O	SIO1 input/output 0
32	GPIO27	I/O	General-purpose input/output 27
	COMP1L	O	Comparator COMP1L result output
	PWM1B	O	PWM1 output B
	PWM2B	O	PWM2 output B
	SIO1_1	I/O	SIO1 input/output 1
33	GPIO28	I/O	General-purpose input/output 28
	COMP2H	O	Comparator COMP2H result output
	PWM2B	O	PWM2 output B
	PWM3A	O	PWM3 output A
	SIO1_2	I/O	SIO1 input/output 2
34	GPIO29	I/O	General-purpose input/output 29
	COMP2L	O	Comparator COMP2L result output
	PWM3B	O	PWM3 output B
	SIO1_3	I/O	SIO1 input/output 3
35	DVDD	S	Digital power, <b>add 0.1uF bypass ceramic cap to DVSS</b>
36	GPIO38	I/O	General-purpose input/output 38
	SPI_SCLK	I/O	SPI clock input/output
	UART_TXD	O	UART transmit data
	UART_RXD	I	UART receive data
	PWMSOCA	O	PWM SOCA signal output for monitoring
	SIO1_12	I/O	SIO1 input/output 12
37	GPIO39	I/O	General-purpose input/output 39
	SPI_SFRM	I/O	SPI frame signal
	UART_RXD	I	UART receive data
	UART_TXD	O	UART transmit data
	PWMSOCB	O	PWM SOCB signal output for monitoring
	SIO1_13	I/O	SIO1 input/output 13
38	GPIO40	I/O	General-purpose input/output 40
	SPI_MOSI	I/O	SPI master output, slave input

Pin	Signal	Type <sup>(1)</sup>	Description
	SPI_MISO	I/O	SPI master input, slave output
	I2C_SCL	I/O	I <sup>2</sup> C clock
	PWMSOCC	O	PWM SOCC signal output for monitoring
	SIO1_14	I/O	SIO1 input/output 14
39	GPIO41	I/O	General-purpose input/output 41
	SPI_MISO	I/O	SPI master input, slave output
	SPI_MOSI	I/O	SPI master output, slave input
	I2C_SDA	I/O	I <sup>2</sup> C data
	PWMSYNCO	O	PWMSYNCO signal output for monitoring
	SIO1_15	I/O	SIO1 input/output 15
40	GPIO42	I/O	General-purpose input/output 42
	I2C_SCL	I/O	I <sup>2</sup> C clock
	COMP6H	O	Comparator COMP6H result output
	SPI_SCLK	I/O	SPI clock input/output
	SIO1_16	I/O	SIO1 input/output 16
41	GPIO43	I/O	General-purpose input/output 43
	I2C_SDA	I/O	I <sup>2</sup> C data
	COMP6L	O	Comparator COMP6L result output
	SPI_SFRM	I/O	SPI frame signal
	SIO1_17	I/O	SIO1 input/output 17
42	BOOT (GPIO47)	I/O	Boot pin (General-purpose input/output 47)
	SIO2_3	I/O	SIO2 input/output 3
43	XRSTn	I	Device reset pin, reset the device when low
44	TRSTn	I	JTAG reset pin, reset the JTAG when low
45	GPIO48	I/O	General-purpose input/output 48
	TCK/SWCK	I	JTAG clock or SWD clock
	COMP0H	O	Comparator COMP0H result output
	COMP3H	O	Comparator COMP3H result output
	SIO2_4	I/O	SIO2 input/output 4
46	GPIO49	I/O	General-purpose input/output 49
	TMS/SWD	I/O	JTAG mode select or SWD data
	COMP0L	O	Comparator COMP0L result output

Pin	Signal	Type <sup>(1)</sup>	Description
	COMP3L	O	Comparator COMP3L result output
	SIO2_5	I/O	SIO2 input/output 5
	<b>Note: when TRSTn is HIGH, this pin always works as TMS/SWD and can't be configured as other functions.</b>		
47	GPIO50	I/O	General-purpose input/output 50
	TDI	I	JTAG data input
	SWCK(CAU)	I	SWD clock for CAU
	COMP1H	O	Comparator COMP1H result output
	COMP4H	O	Comparator COMP4H result output
	SIO2_6	I/O	SIO2 input/output 6
<b>Note: when TRSTn is HIGH, this pin always works as TDI or SWCK(CAU) and can't be configured as other functions.</b>			
48	GPIO51	I/O	General-purpose input/output 51
	TDO	O	JTAG data output
	SWD(CAU)	I/O	SWD data for CAU
	COMP1L	O	Comparator COMP1L result output
	COMP4L	O	Comparator COMP4L result output
	SIO2_7	I/O	SIO2 input/output 7
<b>Note: when TRSTn is HIGH, this pin always works as TDO or SWD(CAU) and can't be configured as other functions.</b>			
49	DVDD	S	Digital power, <b>add 0.1uF bypass ceramic cap to DVSS</b>
50	VCAP12	S	1.2V power, <b>add 0.1uF bypass ceramic cap to DVSS</b>
51	GPIO58	I/O	General-purpose input/output 58
	PWM6A	O	PWM6 output A
	PWM5A	O	PWM5 output A
	SIO2_14	I/O	SIO2 input/output 14
52	GPIO59	I/O	General-purpose input/output 59
	PWM4B	O	PWM4 output B
	PWM5B	O	PWM5 output B
	SIO2_15	I/O	SIO2 input/output 15

[1] I = digital input, O = digital output, AI = analog input, AO = analog out, S = supply.

[2] PWMSOC signal is logic OR of PWMSOCA, PWMSOCB and PWMSOCC signal.

[3] All GPIO pins can be configured as ECAP input or output.

### 3.6 PGA input channel selection

For the six on-MCU PGA's, each PGA has two 1-of-8 multiplexers (MUX) for input channel selection, one is for positive input (PGA<sub>x</sub>\_P, x = 0~5) and the other is for negative input (PGA<sub>x</sub>\_N, x = 0~5). The input channel selection table is shown below.

**Table 3-6: PGA0/1/2 input channel selection**

MUX Value	PGA0_P	PGA0_N	PGA1_P	PGA1_N	PGA2_P	PGA2_N
0	GND	GND	GND	GND	GND	GND
1	DAC0	DAC0	DAC0	DAC0	DAC0	DAC0
2	DAC2	DAC3	AATEST	VREF12	ADC10	VDD12
3	ADC0	ADC1	ADC0	ADC2	ADC0	ADC3
4	ADC2	ADC3	ADC2	ADC3	ADC2	ADC1
5	ADC4	ADC5	ADC4	ADC5	ADC4	ADC5
6	ADC6	ADC7	ADC6	ADC7	ADC6	ADC7
7	ADC8	ADC9	ADC8	ADC9	ADC8	ADC9

**Table 3-7: PGA3/4/5 input channel selection**

MUX Value	PGA3_P	PGA3_N	PGA4_P	PGA4_N	PGA5_P	PGA5_N
0	GND	GND	GND	GND	GND	GND
1	DAC1	DAC1	DAC1	DAC1	DAC1	DAC1
2	DAC4	DAC5	ADC11	ADC0	TSEN1	TSEN0
3	ADC10	ADC11	ADC10	ADC12	ADC10	ADC13
4	ADC12	ADC13	ADC12	ADC13	ADC12	ADC11
5	ADC14	ADC15	ADC14	ADC15	ADC14	ADC15
6	ADC16	ADC17	ADC16	ADC17	ADC16	ADC17
7	ADC18	ADC19	ADC18	ADC19	ADC18	ADC19

[1] TSEN0 is output 0 of T-Sensor and TSEN1 is output 1 of T-Sensor.

### 3.7 GPIO pin function and state after reset

Table 3-8: GPIO pin function and state after reset

Pin Name	Default Function	Default State
GPIO0	ADC0	Floating
GPIO1	ADC1	Floating
GPIO2	ADC2	Floating
GPIO3	ADC3	Floating
GPIO4	ADC4	Floating
GPIO5	ADC5	Floating
GPIO6	ADC6	Floating
GPIO7	ADC7	Floating
GPIO8	ADC8	Floating
GPIO9	ADC9	Floating
GPIO10	ADC10	Floating
GPIO11	ADC11	Floating
GPIO12	ADC12	Floating
GPIO13	ADC13	Floating
GPIO14	ADC14	Floating
GPIO15	ADC15	Floating
GPIO16	ADC16	Floating
GPIO17	ADC17	Floating
GPIO18	ADC18	Floating
GPIO19	ADC19	Floating
GPIO20	GPIO20	Pull up
GPIO21	GPIO21	Pull up
GPIO22	GPIO22	Pull up
GPIO23	GPIO23	Pull up
GPIO24	GPIO24	Floating
GPIO25	GPIO25	Floating
GPIO26	GPIO26	Floating
GPIO27	GPIO27	Floating
GPIO28	GPIO28	Floating
GPIO29	GPIO29	Floating
GPIO30	GPIO30	Pull up
GPIO31	GPIO31	Pull up
GPIO32	GPIO32	Floating
GPIO33	GPIO33	Floating
GPIO34	GPIO34	Floating
GPIO35	GPIO35	Floating
GPIO36	GPIO36	Floating
GPIO37	GPIO37	Floating



Pin Name	Default Function	Default State
GPIO38	GPIO38	Pull up
GPIO39	GPIO39	Pull up
GPIO40	GPIO40	Pull up
GPIO41	GPIO41	Pull up
GPIO42	GPIO42	Pull up
GPIO43	GPIO43	Pull up
GPIO44	GPIO44	Pull up
GPIO45	GPIO45	Pull up
GPIO46	GPIO46	Pull up
GPIO47	GPIO47	Pull up
GPIO48	GPIO48	Pull up
GPIO49	GPIO49	Pull up
GPIO50	GPIO50	Pull up
GPIO51	GPIO51	Pull up
GPIO52	GPIO52	Floating
GPIO53	GPIO53	Floating
GPIO54	GPIO54	Floating
GPIO55	GPIO55	Floating
GPIO56	GPIO56	Floating
GPIO57	GPIO57	Floating
GPIO58	GPIO58	Floating
GPIO59	GPIO59	Floating
GPIO60	GPIO60	Floating
GPIO61	GPIO61	Floating

## 4 Memory mapping

The memory map of SPC1198 is shown in Figure 4-1 to Figure 4-2.

**Figure 4-1: SPC1198 memory map with Cache disabled**

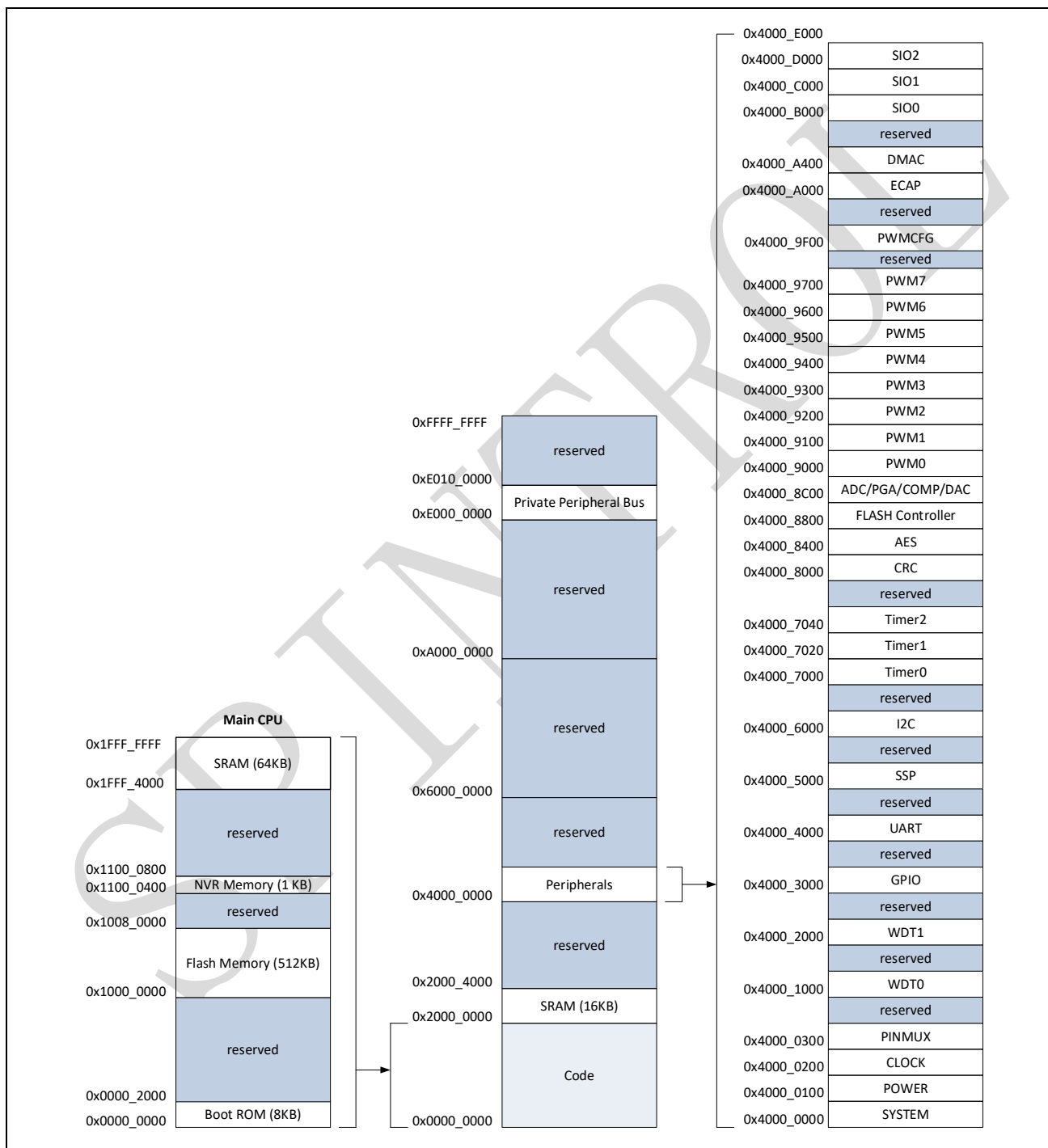
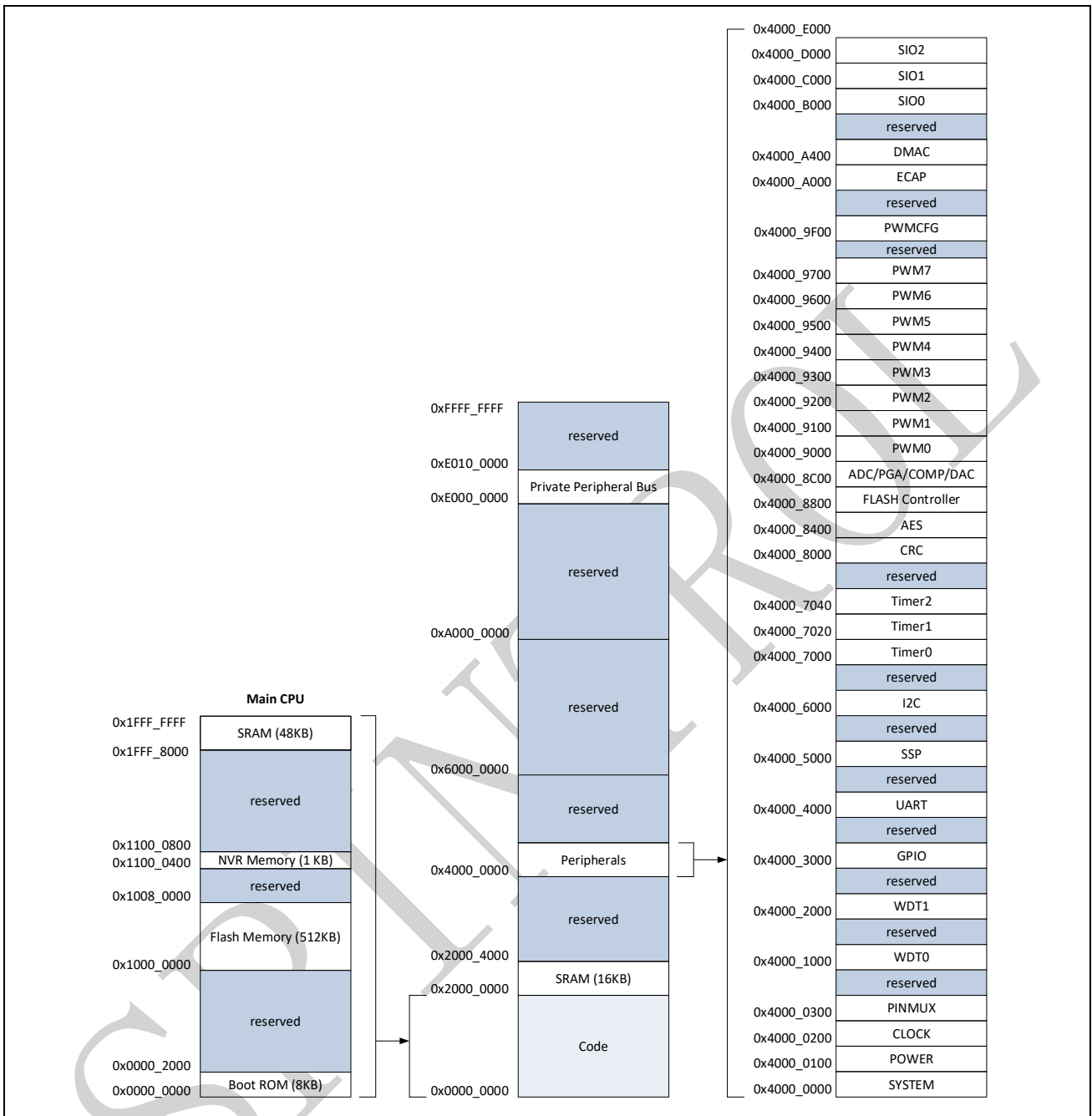

Figure 4-2: SPC1198 memory map with Cache enabled



## 5 Electrical characteristics

### 5.1 Absolute maximum ratings

Table 5-1: Absolute maximum ratings <sup>(1)(2)</sup>

Symbol	Parameter	Min	Max	Unit
V <sub>DD</sub>	Supply voltage, with respect to V <sub>SS</sub>	-0.3	4.6	V
V <sub>DDA</sub>	Analog voltage, with respect to V <sub>SSA</sub>	-0.3	4.6	V
V <sub>IN</sub>	Input voltage (V <sub>DD</sub> = 3.3 V)	-0.3	4.6	V
V <sub>O</sub>	Output voltage	-0.3	4.6	V
I <sub>IC</sub>	Input clamp current	-20	+20	mA
I <sub>OC</sub>	Output clamp current	-20	+20	mA
T <sub>J</sub>	Junction temperature <sup>(3)</sup>	-40	+125	°C
T <sub>A</sub>	Ambient temperature <sup>(3)</sup>	-40	+105	°C
T <sub>stg</sub>	Storage temperature <sup>(3)</sup>	-65	+150	°C

- [1] Stresses beyond those listed under absolute maximum ratings may cause permanent damage to the device. These are stress ratings only, and functional operation of the device at these is not implied.
- [2] All voltage values are with respect to V<sub>SS</sub>, unless otherwise noted.
- [3] Long-term high-temperature storage or extended use at maximum temperature conditions may result in a reduction of overall device life.

## 5.2 Recommended operating conditions

Table 5-2: Recommended operating conditions

Symbol	Parameter	Conditions	Min	Nom	Max	Unit
$V_{DD}$	Supply voltage	-	2.97	3.3	3.63	V
$V_{SS}$	Supply ground	-	-	0	-	V
$V_{DDA}$	Analog supply voltage	-	2.97	3.3	3.63	V
$V_{SSA}$	Analog ground	-	-	0	-	V
$V_{IH}$	High-level input voltage	$V_{DD} = 3.3\text{ V}$	2.0	-	$V_{DD}+0.3$	V
$V_{IL}$	Low-level input voltage	$V_{DD} = 3.3\text{ V}$	$V_{SS}-0.3$	-	0.8	V
$I_{OH}$	High-level output source current when $V_{OH} = V_{OH(MIN)}$	STRENGTH=0 STRENGTH=1 STRENGTH=2 STRENGTH=3	-	-	5 10 15 20	mA
$I_{OL}$	Low-level output sink current when $V_{OL} = V_{OL(MAX)}$	STRENGTH=0 STRENGTH=1 STRENGTH=2 STRENGTH=3	-	-	5 10 15 20	mA
$T_J$	Junction temperature	-	-40	-	+125	°C
$T_A$	Ambient temperature	-	-40	-	+105	°C

## 5.3 I/O Electrical characteristics

Table 5-3: I/O Electrical characteristics

Symbol	Parameter	Conditions	Min	Typ	Max	Unit
$V_{OH}$	High-level output voltage	$I_{OH} = I_{OH\text{ MAX}}$	$V_{DD}-0.4$	-	-	V
$V_{OL}$	Low-level output voltage	$I_{OL} = I_{OL\text{ MAX}}$	-	-	0.4	V
$V_{IH}$	High-level input voltage	$V_{DD} = 3.3\text{ V}$	2.0	-	$V_{DD}+0.3$	V
$V_{IL}$	Low-level input voltage	$V_{DD} = 3.3\text{ V}$	$V_{SS}-0.3$	-	0.8	V
$I_{OH}$	High-level output source current when $V_{OH} = V_{OH(MIN)}$	STRENGTH=0 STRENGTH=1 STRENGTH=2 STRENGTH=3	-	-	5 10 15 20	mA
$I_{OL}$	Low-level output sink current when $V_{OL} = V_{OL(MAX)}$	STRENGTH=0 STRENGTH=1 STRENGTH=2	-	-	5 10 15	mA

Symbol	Parameter	Conditions	Min	Typ	Max	Unit
		STRENGTH=3			20	
$I_{IL}$	Low-level input current (Pin with pull-up and pull-down disabled)	$V_{DD} = 3.3V,$ $V_{IH} = 0V$	-	-	2	$\mu A$
$I_{IH}$	High-level input current (Pin with pull-up and pull-down disabled)	$V_{DD} = 3.3V,$ $V_{IH} = V_{DD}$	-	-	2	$\mu A$
$R_{PU}$	Input pull-up resistor	$V_{IO} = 0V$	-	41	-	$k\Omega$
$R_{PD}$	Input pull-down resistor	$V_{IO} = V_{DD}$	-	42	-	$k\Omega$

SPIN TROL

## 5.4 Power consumption summary

Typical current consumption

In operational mode, the SPC1198 is placed under the following conditions:

- All I/O pins are in input mode and left unconnected;
- All peripherals (including analog module) are enabled;
- All peripheral clocks are as fast as HCLK (frequency division is 1), except SSP (Max 50 MHz) I2C (Max 50 MHz), PCLK (Max 50 MHz) and DGCLK (Max 50 MHz);
- All clock modules are enabled;
- Select PLL clock as system clock source.

In idle mode, the SPC1198 is placed under the following conditions:

- All I/O pins are in input mode and left unconnected;
- All peripherals (including analog module) are clocked off or disabled;
- Clock modules (PLL, RCO1 and XO) are disabled;
- Select RCO0 as system clock source with low-frequency mode enabled.

In deep sleep mode, the SPC1198 is placed under the following conditions:

- All I/O pins are in input mode and left unconnected;
- All peripherals (including analog module) are clocked off or disabled;
- Clock modules (PLL, RCO1 and XO) are disabled;
- 1.2V LDO is shut down to 0V.

The typical current consumption of SPC1198 measured from  $V_{DD}$  is shown in Table 5-4 and Table 5-5. The operational current consumption over various HCLK frequency is shown in Figure 5-1.

**Table 5-4: SPC1198 typical current consumption (Run in FLASH)**

Mode	Conditions			-40°C	25 °C	125°C	Unit
	f <sub>HCLK</sub>	f <sub>PCLK</sub>	f <sub>PLL</sub>				
Operational	200 MHz <sup>(2)</sup>	50 MHz	200 MHz	114.35	136.71	160.43	mA
	175 MHz <sup>(2)</sup>	43.75 MHz	175 MHz	102.02	126.86	150.96	mA
	168 MHz <sup>(2)</sup>	42 MHz	168 MHz	100.01	124.02	147.59	mA
	150 MHz <sup>(2)</sup>	50 MHz	150 MHz	93.624	117.24	142.93	mA
	125 MHz <sup>(2)</sup>	41.67 MHz	125 MHz	83.743	107.54	131.23	mA
	100 MHz	50 MHz	100 MHz	76.192	97.895	120.52	mA
	75 MHz	37.5 MHz	75 MHz	66.135	88.168	110.21	mA
	50 MHz	50 MHz	50 MHz	57.331	78.785	99.493	mA
32 MHz	32 MHz	32 MHz	50.233	71.735	92.334	mA	

Mode	Conditions			-40°C	25 °C	125°C	Unit
	f <sub>HCLK</sub>	f <sub>PCLK</sub>	f <sub>PLL</sub>				
	25 MHz	25 MHz	25 MHz	48.797	68.729	88.642	mA
Idle	110 Hz	110 Hz	-	6.7231	9.6037	13.484	mA
Sleep	-	-	-	10	10	10	uA

[1] Measured at V<sub>DD</sub> = 3.3 V.

[2] SIO module clock frequency is f<sub>HCLK</sub> / 2.

**Table 5-5: SPC1198 typical current consumption (Run in RAM)**

Mode	Conditions			-40 °C	25 °C	125 °C	Unit
	f <sub>HCLK</sub>	f <sub>PCLK</sub>	f <sub>PLL</sub>				
Operational	200 MHz <sup>(2)</sup>	50 MHz	200 MHz	113.45	134.80	159.24	mA
	175 MHz <sup>(2)</sup>	43.75 MHz	175 MHz	100.95	125.25	149.77	mA
	168 MHz <sup>(2)</sup>	42 MHz	168 MHz	98.743	122.53	146.23	mA
	150 MHz <sup>(2)</sup>	50 MHz	150 MHz	92.433	115.98	140.84	mA
	125 MHz <sup>(2)</sup>	41.67 MHz	125 MHz	82.558	106.47	130.01	mA
	100 MHz	50 MHz	100 MHz	74.996	97.137	119.02	mA
	75 MHz	37.5 MHz	75 MHz	64.932	87.666	108.98	mA
	50 MHz	50 MHz	50 MHz	56.001	78.487	98.102	mA
	32 MHz	32 MHz	32 MHz	48.983	71.509	91.019	mA
	25 MHz	25 MHz	25 MHz	47.522	68.530	87.333	mA
Idle	110 Hz	110 Hz	-	6.6432	9.5224	13.421	mA

[1] Measured at V<sub>DD</sub> = 3.3 V.

[2] SIO module clock frequency is f<sub>HCLK</sub> / 2.

**Figure 5-1: Typical operational current versus frequency**

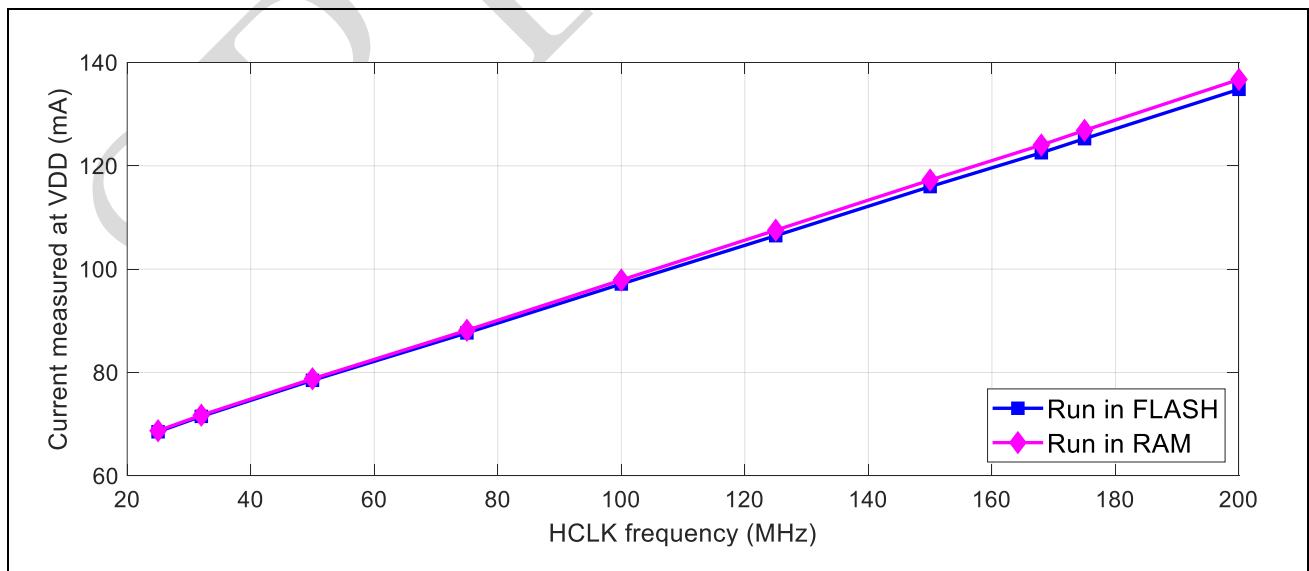



## On-chip peripheral current consumption

The current consumption of the on-chip peripherals is given in Table 5-6. The MCU is placed under the following conditions:

- All I/O pins are in input mode and left unconnected;
- All peripherals(including analog module, RCO0 and XO) are disabled unless otherwise mentioned;
- The given value is calculated by measuring the current consumption
  - With all peripherals clocked disabled
  - With only one peripheral enabled

**Table 5-6: Peripheral current consumption**

Peripherals <sup>(1)</sup>		Conditions	-40 °C	25 °C	125 °C	Unit
BOD		Select RCO0 as system clock source; All other peripherals use default settings; Close PLL, XO, RCO1 and RCO0 after disabling or enabling BOD module	0.1	0.1	0.1	mA
ADC	Analog <sup>(3)</sup>	Select PLL clock as system clock source; All peripheral clocks are as fast as HCLK; $f_{HCLK} = 128 \text{ MHz}$ , $f_{PCLK} = 32 \text{ MHz}$ , $f_{PLL} = 128 \text{ MHz}$	15.99	16.52	17.05	mA
	Digital		2.12	2.31	2.55	mA
T-Sensor			0.16	0.16	0.16	mA
PGA <sup>(4)</sup>			4.10	4.10	4.10	mA
DAC			0.18	0.18	0.18	mA
Comparator			0.08	0.08	0.08	mA
CAU			200MHz HCLK	6.001	6.263	6.612
UART		UART clock 200MHz, 256000 bps	0.416	0.456	0.901	mA
I2C		I2C clock 50MHz, 3.4Mbps	0.288	0.312	0.344	mA
SSP		SSP clock 50MHz, 50Mbps	0.321	0.356	0.391	mA
PWM		PWM clock 200MHz	1.065	1.184	1.314	mA
ECAP		ECAP clock 200MHz	0.349	0.360	0.372	mA
WDT		WDT clock 200MHz	0.187	0.235	0.286	mA
TMR		TMR clock 200MHz	0.301	0.337	0.374	mA
SIO		SIO clock 100MHz	5.193	5.733	6.225	mA
FLASH		HCLK clock 200MHz	0.662	0.716	0.771	mA
XO		Use RCO0 as input for 200MHz PLL	0.561	0.624	0.681	mA
RCO0		Use XO as input for 200MHz PLL	0.145	0.157	0.169	mA
RCO1		Use XO as input for 200MHz PLL	0.108	0.114	0.121	mA
PLL		XO as HCLK source, $f_{PLL} = 32 \text{ MHz}$	1.812	1.961	2.132	mA

[1] For peripherals with multiple instances, the current quoted is for single modules. For example, the 4.10 mA value quoted for PGA is for one PGA module. So the total 3 PGA module current is 12.30mA.

[2] Values are measured at  $V_{DD} = 3.3 \text{ V}$ .

[3] ADC analog current contain ADC analog module, bandgap and ADC reference buffer.

[4] The Bandgap must be enabled when enabling ADC (Analog Part), T-sensor, PGA, DAC and comparator.

### 5.5 Internal 1.2V regulator characteristics

Table 5-7: Internal 1.2V regulator characteristics

Symbol	Parameter	Conditions	Min	Typ	Max	Unit
V <sub>DD</sub>	Power supply	-	2.97	3.3	3.63	V
VCAP12	Output voltage	Load current = 50mA	1.18	1.20	1.22	V
ΔVCAP12	Load regulation	VCAP12(50mA load) - VCAP12(200mA load)	-	-	30	mV

Figure 5-2: Internal 1.2V regulator load regulation (T<sub>A</sub> = 25 °C)

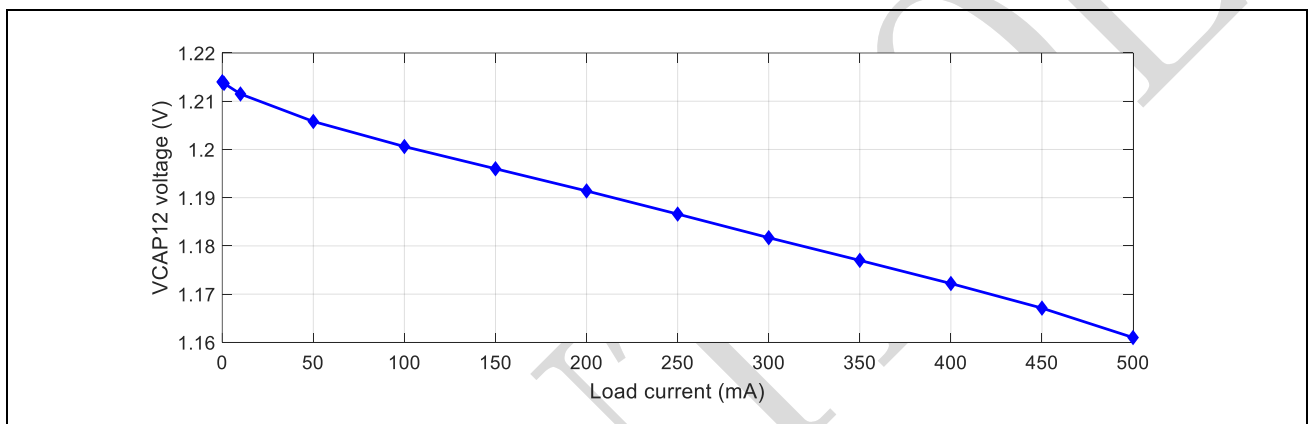
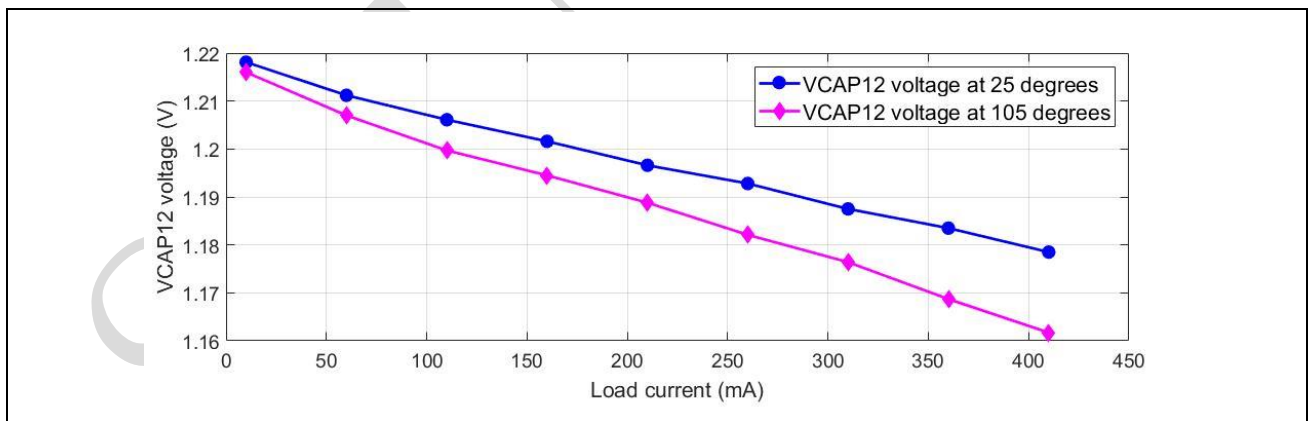

Figure 5-3: Internal 1.2V regulator load regulation with different temperature



## 5.6 BOD characteristics

Table 5-8: BOD characteristics

Symbol	Parameter	Conditions	Min	Typ	Max	Unit
V <sub>DDA</sub>	Power supply	-	2.97	3.3	3.63	V
V <sub>DD33H_Asset</sub>	VDD33 too high assert threshold	-	-	3.42	-	V
V <sub>DD33H_Deassert</sub>	VDD33 too high de-assert threshold	-	-	3.31	-	V
V <sub>DD33L_Asset</sub>	VDD33 too low assert threshold	-	-	2.58	-	V
V <sub>DD33L_Deassert</sub>	VDD33 too low de-assert threshold	-	-	2.65	-	V
V <sub>DD12H_Asset</sub>	VDD12 too high assert threshold	-	-	1.33	-	V
V <sub>DD12H_Deassert</sub>	VDD12 too high de-assert threshold	-	-	1.31	-	V
V <sub>DD12L_Asset</sub>	VDD12 too low assert threshold <sup>(1)</sup>	-	-	0.94	-	V
V <sub>DD12L_Deassert</sub>	VDD12 too low de-assert threshold <sup>(1)</sup>	-	-	0.97	-	V

[1] The characteristics of VDD12 too low 0 and VDD12 too low 1 are the same.

## 5.7 RCO characteristics

Table 5-9: RCO characteristics

Symbol	Parameter	Conditions	Min	Typ	Max	Unit
V <sub>DDA</sub>	Power supply	-	2.97	3.3	3.63	V
F <sub>RCO</sub>	RCO frequency at room temperature	T <sub>J</sub> = 25 °C	31.936	32.00	32.064	MHz
ACC <sub>RCO</sub>	RCO frequency accuracy (RCO frequency variation versus temperature)	T <sub>J</sub> = -40~125 °C	-1	-	1	%

## 5.8 PLL characteristics

Table 5-10: PLL characteristics

Symbol	Parameter	Conditions	Min	Typ	Max	Unit
V <sub>DDA</sub>	Power supply	-	2.97	3.3	3.63	V
F <sub>VCO</sub>	VCO frequency	-	400	500	600	MHz
F <sub>pfid</sub>	Phase-Frequency Detector (PFD) input frequency	-	4	-	8	MHz
t <sub>LOCK</sub>	Locking time	-	-	-	15	us

## 5.9 XO characteristics

Table 5-11: XO characteristics

Symbol	Parameter	Conditions	Min	Typ	Max	Unit
V <sub>DDA</sub>	Power supply	-	2.97	3.3	3.63	V
F <sub>XO</sub>	XO frequency	-	1	-	66	MHz

The negative resistance of the on-chip crystal oscillator at different temperature is shown in [Figure 5-4](#) ~ [Figure 5-7](#). The loading capacitor CL\_eff is defined as equivalent capacitance seen by the on-chip crystal.

Figure 5-4: The negative resistance of the on-chip crystal oscillator at 50°C

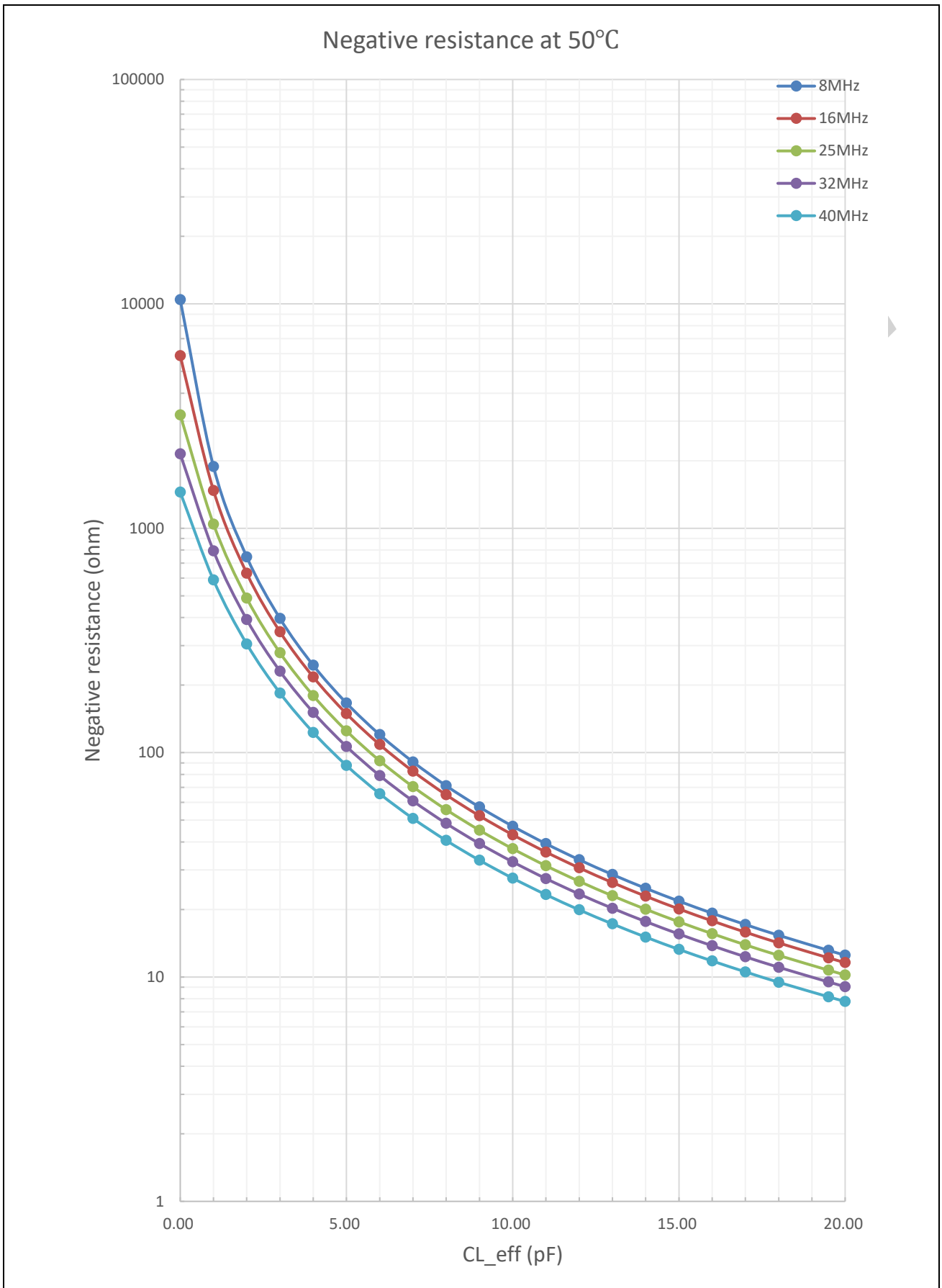

Figure 5-5: The negative resistance of the on-chip crystal oscillator at 85°C

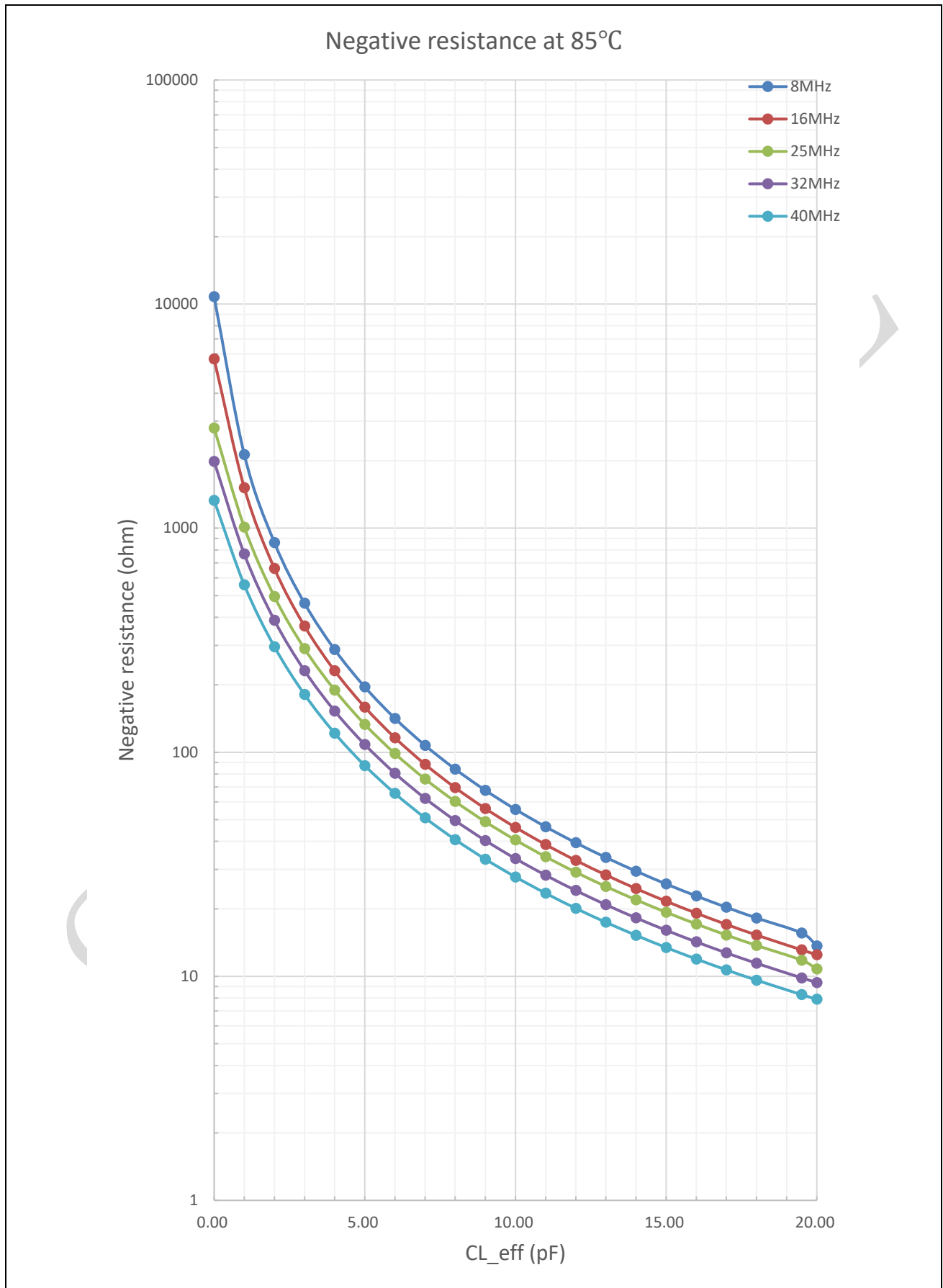

Figure 5-6: The negative resistance of the on-chip crystal oscillator at 100°C

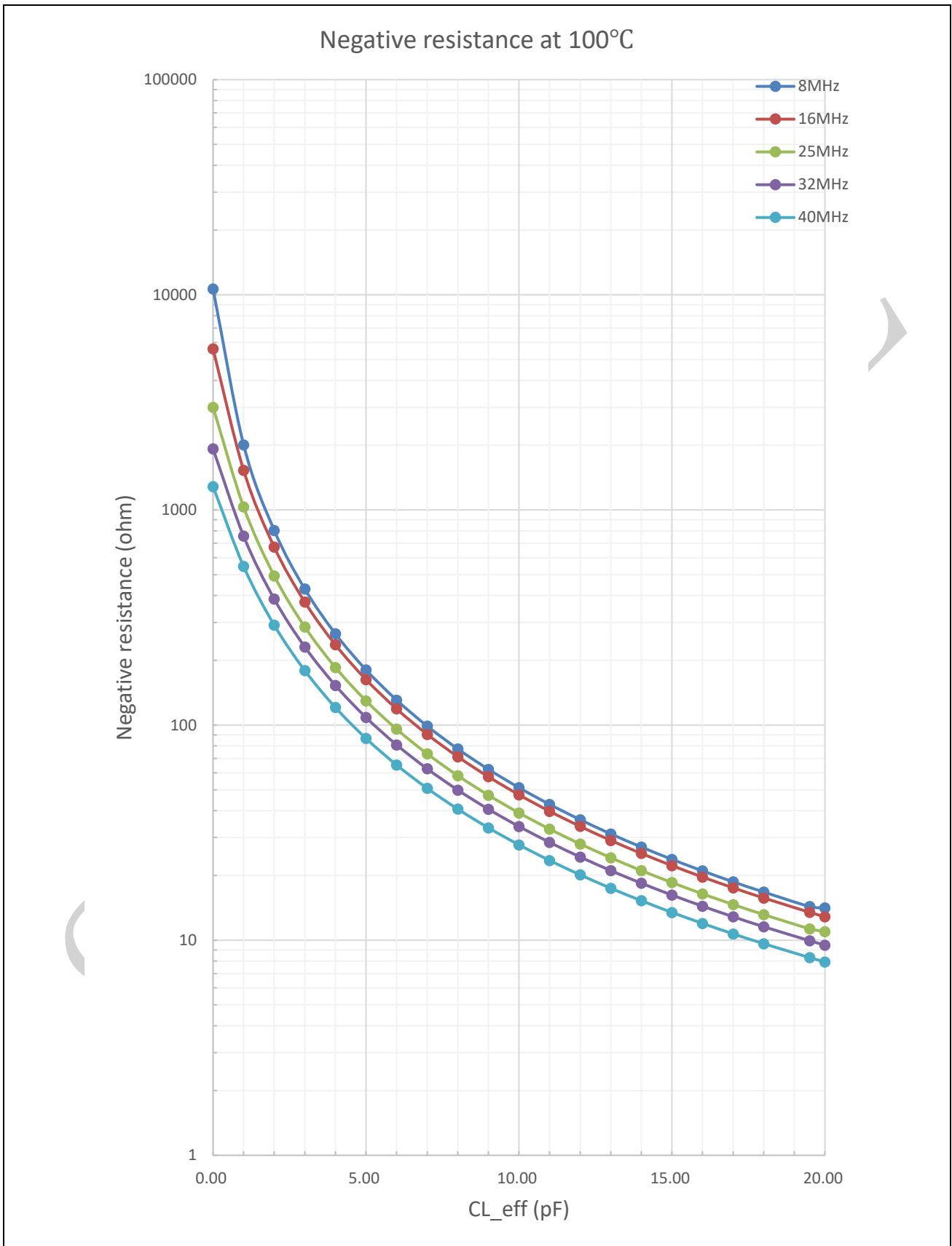
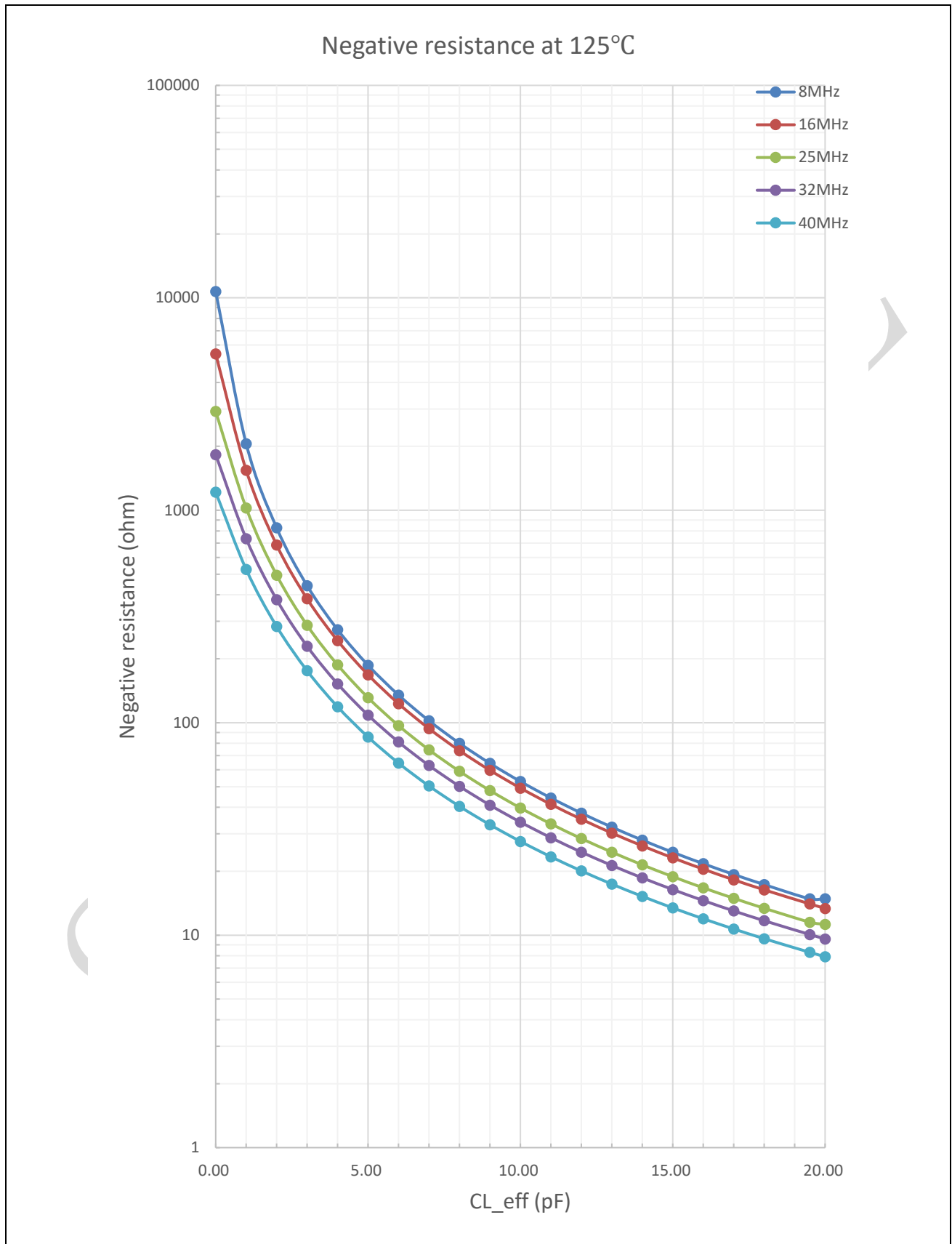

Figure 5-7: The negative resistance of the on-chip crystal oscillator at 125°C





## 5.10 14-bit ADC characteristics

Table 5-12: ADC characteristics

Symbol	Parameter	Conditions	Min	Typ	Max	Unit
V <sub>DDA</sub>	Power supply	-	2.97	3.3	3.63	V
N <sub>R</sub>	Resolution	No missing code. Monotonic	14	-	-	bit
F <sub>S</sub>	Conversion speed <sup>(1)</sup>	-	-	-	4	MSPS
V <sub>AIN</sub>	Input voltage range	-	0	-	V <sub>DDA</sub>	V
V <sub>REF</sub>	Reference voltage	-	1.194	1.2	1.206	V
I <sub>PAD</sub>	Operational current	V <sub>DDA</sub> = 3.3 V	-	17.1	21	mA
INL	Integral linearity error	-	-3.0	-	3.0	LSB
DNL	Differential linearity	-	-1.0	-	1.0	LSB
E <sub>OFF</sub>	Offset error <sup>(2)</sup>	With calibration	-2	-	2	LSB
E <sub>GAIN</sub>	Gain error <sup>(2)</sup>	With calibration	-4	-	4	LSB
E <sub>OFF2</sub>	Channel to channel offset	-	-3	-	3	LSB
E <sub>GAIN2</sub>	Channel to channel gain error	-	-5	-	5	LSB
T <sub>COEF</sub>	ADC temperature coefficient with internal reference	-	-	26	-	ppm/°C
t <sub>PWRUP</sub>	Power-up time	-	-	-	200	us
ENOB <sub>DC</sub>	DC Noise Floor			12.0		bits
SNR	Signal-to-noise ratio	Fin = 100kHz, Amp = 0.94F <sub>S</sub> , N = 8192	-	75.5	-	dB
THD	Total harmonic distortion		-	-85.0	-	dB
ENOB	Effective number of bits		-	12.2	-	bits
SFDR	Spurious free dynamic range		-	86.0	-	dB
T <sub>SLOPE</sub>	Degrees C of temperature movement per measure ADC LSB change of the temperature sensor	-	-	1.904 <sup>(3)</sup>	-	°C/LSB
T <sub>OFFSET</sub>	ADC output at 25 °C of the temperature sensor	-	-	162.138	-	LSB

[1] Sampling time = 110ns, conversion time = 140ns

[2] Offset and gain can be calibrated automatically by HW.

[3] Can be reduced to 0.24 °C/LSB by PGA.

## 5.11 PGA characteristics

**Table 5-13: PGA characteristics**

Symbol	Parameter	Conditions	Min	Typ	Max	Unit
V <sub>DDA</sub>	Power supply	-	2.97	3.3	3.63	V
V <sub>AIN</sub>	Input voltage range	-	0	-	V <sub>DDA</sub>	V
V <sub>OUT</sub>	Output voltage range	-	0.3	-	V <sub>DDA</sub> -0.3	V
R <sub>IN</sub>	Input impedance	-	-	10	-	MΩ
G	Gain	Single-ended mode	1, 2, 4, 8, 12, 16, 24, 32			-
		Differential mode	2, 4, 8, 16, 24, 32, 48, 64			-
E <sub>GAIN</sub>	Gain error	Differential Gain = 2	-0.5	-	0.5	%
		Differential Gain = 64	-3	-	3	%
V <sub>OS</sub>	Offset	-	-5	-	5	mV
T <sub>OFFSET</sub>	Offset temperature drift	-	-	5	-	μV/°C
SR	Slew rate	Single mode and Loading is ADC sampling capacitor	-	20	-	V/us
		Differential mode and Loading is ADC sampling capacitor	-	40	-	V/us
GBW	Gain band width	Single gain = 1	-	40	-	MHz
		Single gain = 8	-	6.8	-	MHz
		Single gain = 32	-	1.7	-	MHz
		Differential gain = 2	-	20	-	MHz
		Differential gain = 16	-	3.4	-	MHz
		Differential gain = 64	-	0.8	-	MHz
t <sub>settle</sub>	Settle time	Differential gain = 2	-	170 <sup>(1)</sup>	220	ns
		Differential gain = 16	-	400	600	ns
		Differential gain = 64	-	1600	2200	ns
SNR	Signal-to-noise ratio	Differential gain = 2 Fin = 10kHz, Amp = 0.94Fs, N = 8192	-	74.0	-	dB
THD	Total harmonic distortion		-	-78.0	-	dB
ENOB	Effective number of bits		-	11.6	-	bit
SFDR	Spurious free dynamic range		-	82.0	-	dB
SNR	Signal-to-noise ratio	Differential gain = 64 Fin = 10kHz, Amp = 0.94Fs, N = 8192	-	58.0	-	dB
THD	Total harmonic distortion		-	-80.0	-	dB
ENOB	Effective number of bits		-	9.4	-	bit
SFDR	Spurious free dynamic range		-	63.0	-	dB
I	Current consumption	Only one PGA	-	4.16	5.20	mA

[1] Settle time is measured by step input, and differential output change from -2.7V to 2.7V (V<sub>DDA</sub>=3.3V), the time for output to be settled with 1LSB (446μV), guarantee by design.

## 5.12 Analog comparator characteristics

Table 5-14: Comparator characteristics

Symbol	Parameter	Conditions	Min	Typ	Max	Unit
$V_{DDA}$	Power supply	-	2.97	3.3	3.63	V
$V_{OFFSET}$	Offset voltage (Hysteresis voltage=0)	Common mode input voltage = 1.65V	-10	-	10	mV
$V_{HYST}$	Hysteresis voltage(12mV)	-	-	13	-	mV
	Hysteresis voltage(24mV)	-	-	26	-	mV
	Hysteresis voltage(36mV)	-	-	42	-	mV
$t_D$	Delay time – comparator response time to PWM shunt down (Asynchronous)	-	-	50	-	ns

## 5.13 Internal 10-bit DAC characteristics

Table 5-15: DAC characteristics

Symbol	Parameter	Conditions	Min	Typ	Max	Unit
$V_{DDA}$	Power supply	-	2.97	3.3	3.63	V
N	resolution	Monotonic	10	-	-	bit
$V_{FS}$	Full scale value	-	0	-	$V_{DDA}$	V
DNL	Differential linearity	-	-0.5	-	0.5	LSB
INL	Integral linearity	-	-1	-	1	LSB
$E_{OFF}$	Offset error	-	-	5	-	mV
$t_{settle}$	DAC settling time	Design guarantee	-	-	1	us

## 5.14 DAC buffer characteristics

Table 5-16: DAC buffer characteristics

Symbol	Parameter	Conditions	Min	Typ	Max	Unit
$V_{DDA}$	Power supply	-	2.97	3.3	3.63	V
$V_{OUT}$	Output voltage range	-	0.3	-	$V_{DDA}-0.3$	V
$t_{settle}$	Settling time	Design guarantee	-	1	-	us
$E_{OFF}$	Offset error	-	-	3	-	mV
$C_{load}$	Capacitor load	-	-	-	50	pF
$R_{load}$	Resistor load	-	1	-	-	MΩ

Figure 5-8: DAC buffer offset over Input voltage

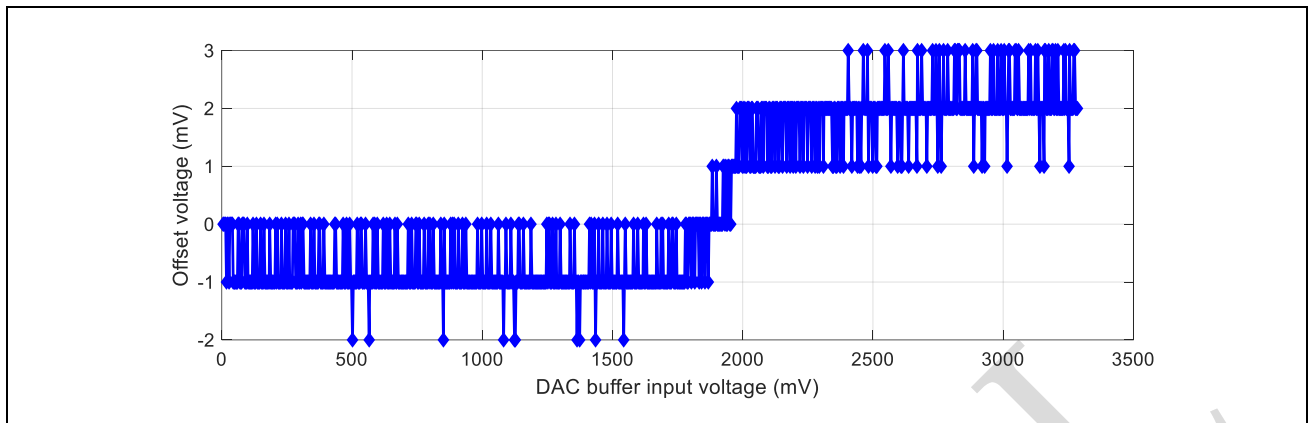

### 5.15 Flash memory characteristics

The characteristics are given at  $T_J = -40$  to  $125\text{ }^\circ\text{C}$  unless otherwise specified.

Table 5-17: Flash memory characteristics

Symbol	Parameter	Conditions	Min	Max	Unit
$t_{read}$	Read access time	-	-	40	ns
$t_{prog,enter}$	Programming mode entry time	-	24	-	us
$t_{prog}$	Program time	-	8	10	us
$t_{prog,exit}$	Programming mode exit time	-	5	-	us
$t_{SE}$	Sector erase time	-	0.8	4	ms
$t_{CE}$	Chip erase time	-	8	10	ms
$N_{cycle}$	Endurance (erase/program cycle)	$T_J = 85\text{ }^\circ\text{C}$	100,000	-	cycles
$t_{retention}$	Data retention duration	$T_J = 85\text{ }^\circ\text{C}$	10	-	years

### 5.16 Electrical sensitivity characteristics

Table 5-18: ESD absolute maximum ratings

Symbol	Parameter	Conditions	Max	Unit	
$V_{ESD(HBM)}$	Electrostatic discharge voltage (Human Body Model)	Ambient temperature $T_A = 25\text{ }^\circ\text{C}$	2000	V	
$V_{ESD(CDM)}$	Electrostatic discharge voltage (Charge Device Model)	Ambient temperature	-	500	V
		$T_A = 25\text{ }^\circ\text{C}$	Corner Pin	750	V

Table 5-19: Electrical sensitivities

Symbol	Parameter	Conditions	Max	Unit
LU	Static latch-up	Ambient temperature $T_A = 85\text{ }^\circ\text{C}$ $V_{DD} = 3.63\text{V}$ , $V_{CAP12} = 1.32\text{V}$	100	mA

## 5.17 Moisture sensitivity characteristics

**Table 5-20: Moisture sensitivity characteristic**

Symbol	Parameter	Conditions	Level	Unit
MSL	Moisture sensitivity level	-	Level 3	-

## 5.18 Thermal resistance characteristics

**Table 5-21: Thermal resistance characteristics (LQFP80 package)**

Symbol	Parameter	Conditions	Typ	Unit
$\theta_{JC}$	Junction-to-case thermal resistance	-	9.82	°C/W
$\theta_{JA}$	Junction-to-ambient thermal resistance	Single layer PCB PCB Copper content = 20%	57.58	°C/W
		4-layer PCB PCB Copper content (Top layer = 20%, Second/Third layer = 100%, Bottom layer = 5%)	41.84	°C/W

[1] The size of PCB test board is 76.2mm x 114.3mm x 1.6mm.

**Table 5-22: Thermal resistance characteristics (LQFP64 package)**

Symbol	Parameter	Conditions	Typ	Unit
$\theta_{JC}$	Junction-to-case thermal resistance	-	19.03	°C/W
$\theta_{JA}$	Junction-to-ambient thermal resistance	Single layer PCB PCB Copper content = 20%	76.52	°C/W
		4-layer PCB PCB Copper content (Top layer = 20%, Second/Third layer = 100%, Bottom layer = 5%)	58.81	°C/W

[1] The size of PCB test board is 76.2mm x 114.3mm x 1.6mm.

**Table 5-23: Thermal resistance characteristics (LQFP52 package)**

Symbol	Parameter	Conditions	Typ	Unit
$\theta_{JC}$	Junction-to-case thermal resistance	-	18.69	°C/W
$\theta_{JA}$	Junction-to-ambient thermal resistance	Single layer PCB PCB Copper content = 20%	68.42	°C/W
		4-layer PCB PCB Copper content (Top layer = 20%, Second/Third layer = 100%, Bottom layer = 5%)	54.61	°C/W

[1] The size of PCB test board is 76.2mm x 114.3mm x 1.6mm.

Table 5-24: Thermal resistance characteristics (LQFP48 package)

Symbol	Parameter	Conditions	Typ	Unit
$\theta_{JC}$	Junction-to-case thermal resistance	-	16.84	°C/W
$\theta_{JA}$	Junction-to-ambient thermal resistance	Single layer PCB PCB Copper content = 20%	72.15	°C/W
		4-layer PCB PCB Copper content (Top layer = 20%, Second/Third layer = 100%, Bottom layer = 5%)	52.37	°C/W

[1] The size of PCB test board is 76.2mm x 114.3mm x 1.6mm.

Table 5-25: Thermal resistance characteristics (QFN52 package)

Symbol	Parameter	Conditions	Typ	Unit
$\theta_{JC}$	Junction-to-case thermal resistance	-	10.03	°C/W
$\theta_{JA}$	Junction-to-ambient thermal resistance	Single layer PCB PCB Copper content = 20%	57.93	°C/W
		4-layer PCB PCB Copper content (Top layer = 20%, Second/Third layer = 100%, Bottom layer = 5%)	34.49	°C/W

[1] The size of PCB test board is 76.2mm x 114.3mm x 1.6mm.

## 5.19 SPI characteristics

Table 5-26: SPI characteristics

Symbol	Parameter	Conditions	Min	Typ	Max	Unit
$f_{SCLK}$	SCLK clock frequency	-	-	-	50	MHz
$t_{SCLK(H)}$	SCLK clock high time	-	10	-	-	ns
$t_{SCLK(L)}$	SCLK clock low time	-	10	-	-	ns
<b>SPI master mode</b>						
$t_{V(MO)}$	Data output valid time	-	-	-	9.5	ns
$t_{H(MO)}$	Data output hold time	-	3.9	-	-	ns
$t_{SU(MI)}$	Data input setup time	-	6	-	-	ns
$t_{H(MI)}$	Data input hold time	-	2	-	-	ns
<b>SPI slave mode</b>						
$t_{SU(SFRM)}$	SFRM enable setup time	-	5.6	-	-	ns
$t_{H(SFRM)}$	SFRM enable hold time	-	1.5	-	-	ns
$t_{A(SO)}$	Data output access time	-	4	-	10	ns
$t_{DIS(SO)}$	Data output disable time	-	4	-	10	ns
$t_{V(SO)}$	Data output valid time	-	-	-	9.5	ns
$t_{H(SO)}$	Data output hold time	-	3.9	-	-	ns
$t_{SU(SI)}$	Data input setup time	-	6	-	-	ns
$t_{H(SI)}$	Data input hold time	-	2	-	-	ns

## 6 Package information

The package type of SPC1198 can be 80-pin LQFP, 64-pin LQFP, 52-pin LQFP, 48-pin LQFP or 52-pin QFN. The detail information is as below.

### 6.1 LQFP80

Figure 6-1: LQFP80–80 pin, 12 x 12 mm low-profile quad flat package outline

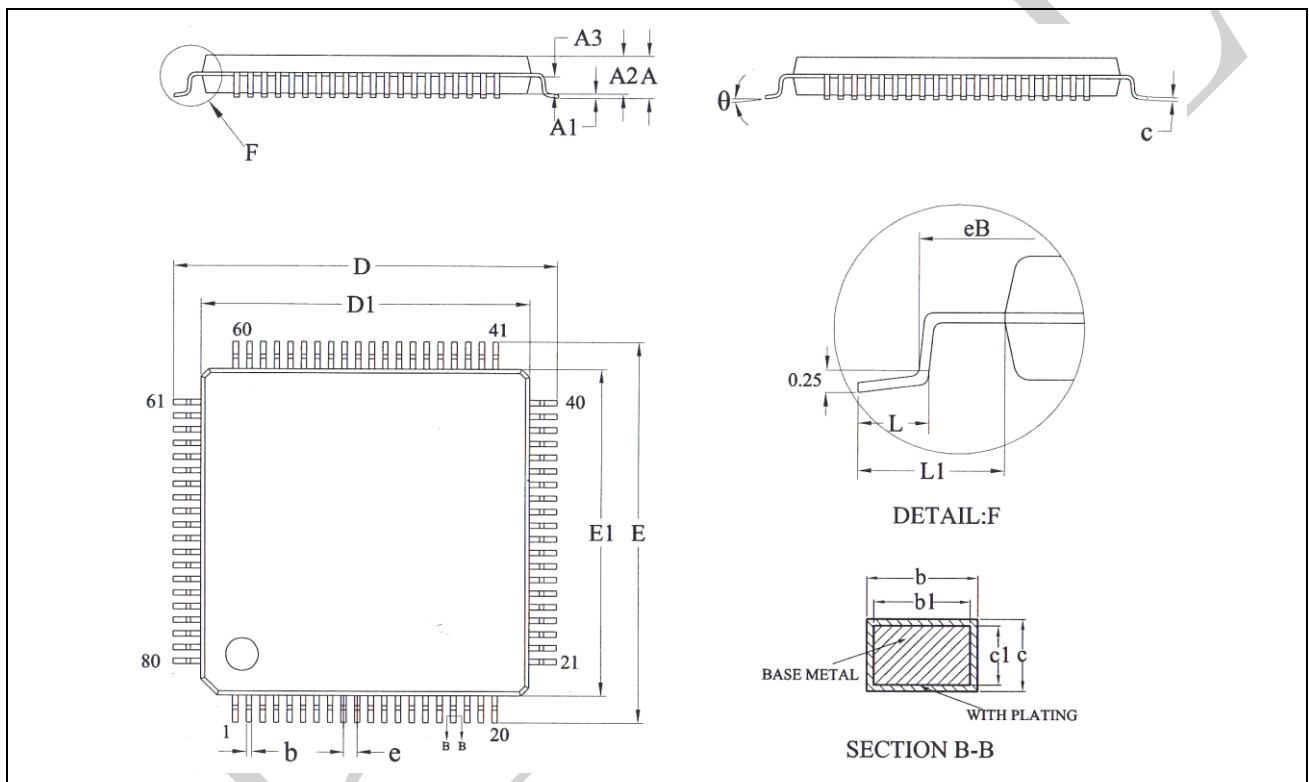

[1] Drawing is not to scale.

Table 6-1: LQFP80–80 pin, 12 x 12 mm low-profile quad flat package mechanical data

Symbol	millimeters		
	Min	Typ	Max
A	-	-	1.60
A1	0.05	-	0.15
A2	1.35	1.40	1.45
A3	0.59	0.64	0.69
b	0.18	-	0.26
b1	0.17	0.20	0.23
c	0.13	-	0.17
c1	0.12	0.13	0.14
D	13.80	14.00	14.20

Symbol	millimeters		
	Min	Typ	Max
D1	11.90	12.00	12.10
E	13.80	14.00	14.20
E1	11.90	12.00	12.10

**Table 6-1: LQFP80–80 pin, 12 x 12 mm low-profile quad flat package mechanical data (continued)**

Symbol	millimeters		
	Min	Typ	Max
eB	13.05	-	13.25
e	-	0.50	-
L	0.45	0.60	0.75
L1	-	1.00REF	-
$\theta$	0	-	$7^\circ$

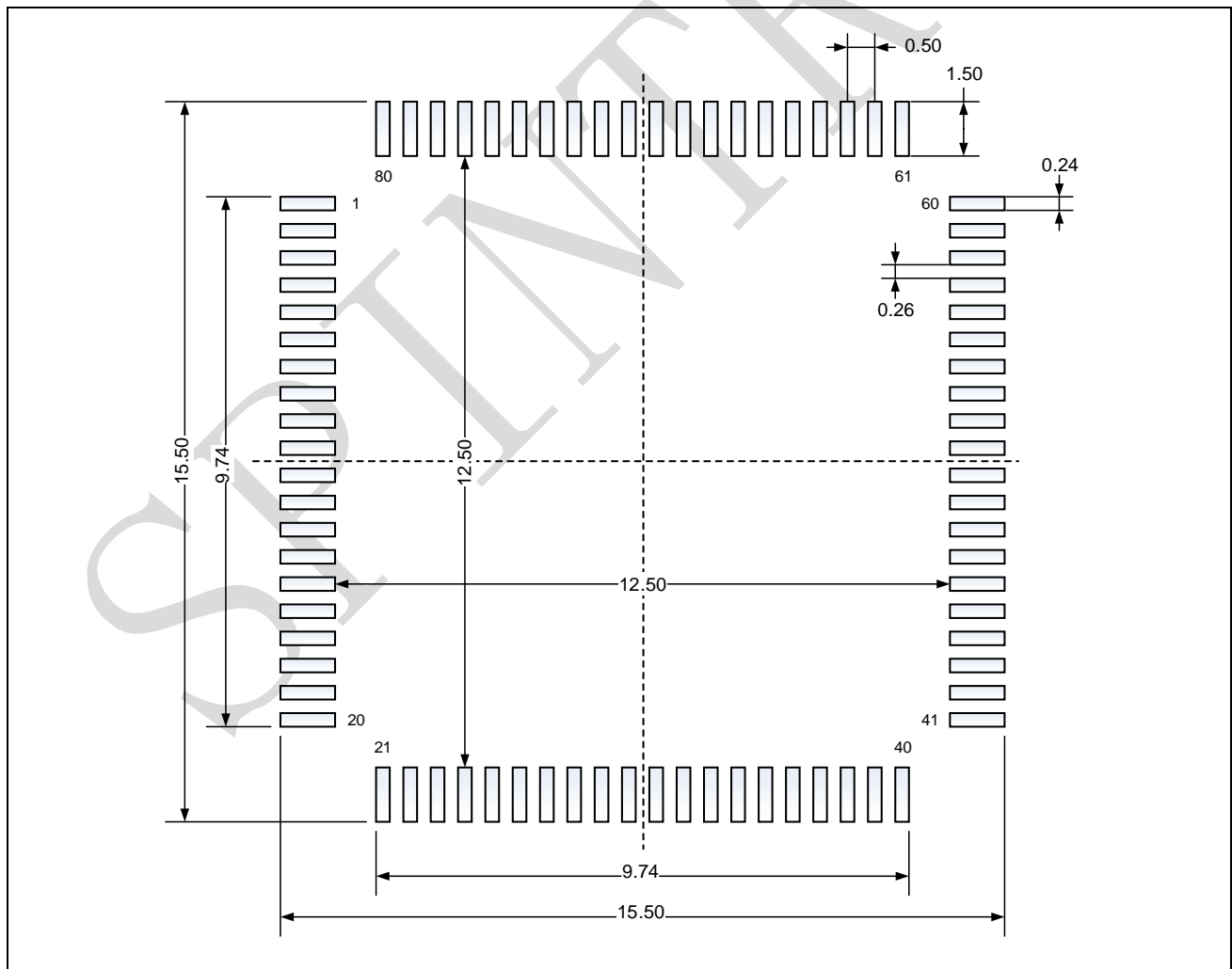
**Figure 6-2: LQFP80–80 pin, 12 x 12 mm low-profile quad flat package recommended footprint**

[1] Dimensions are expressed in millimeters.



## 6.2 LQFP64

Figure 6-3: LQFP64–64 pin, 10 x 10 mm low-profile quad flat package outline

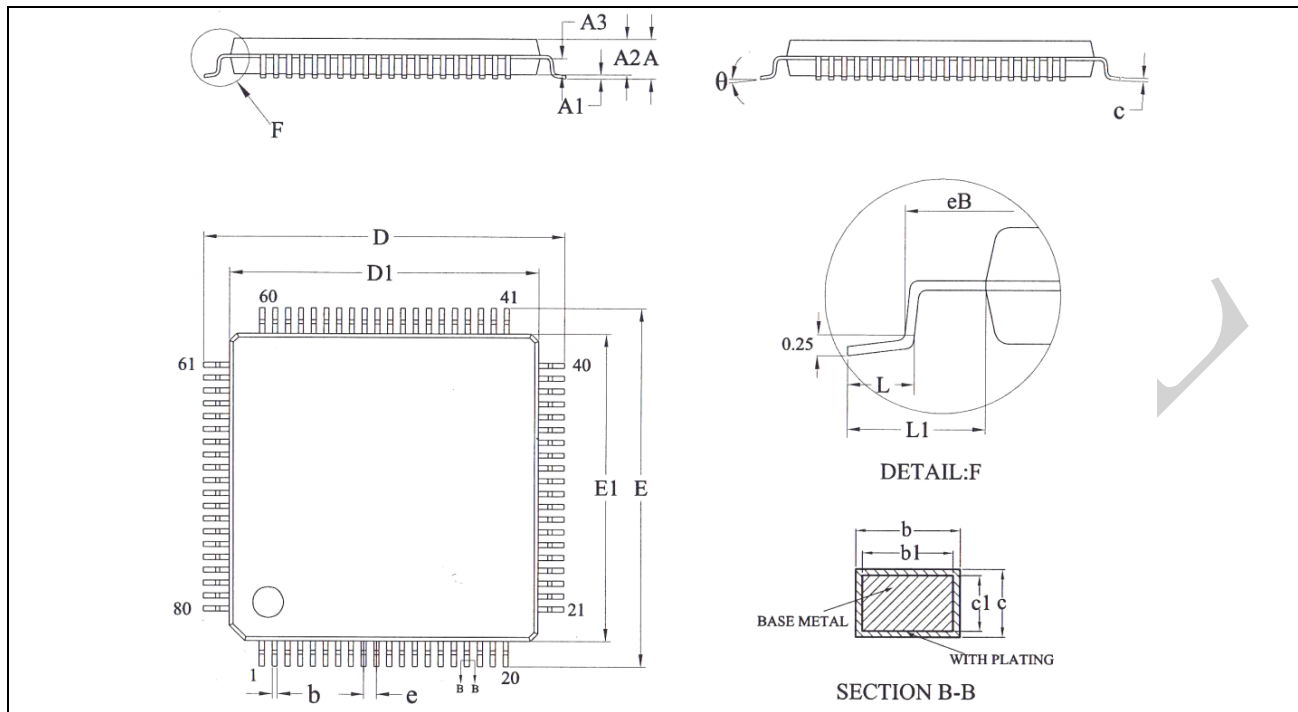

[1] Drawing is not to scale.

Table 6-2: LQFP64–64 pin, 10 x 10 mm low-profile quad flat package mechanical data

Symbol	millimeters		
	Min	Typ	Max
A	-	-	1.60
A1	0.05	-	0.15
A2	1.35	1.40	1.45
A3	0.59	0.64	0.69
b	0.18	-	0.26
b1	0.17	0.20	0.23
c	0.13	-	0.17
c1	0.12	0.13	0.14
D	11.80	12.00	12.20
D1	9.90	10.00	10.10
E	11.80	12.00	12.20
E1	9.90	10.00	10.10
eB	11.05	-	11.25
e	-	0.50	-
L	0.45	0.60	0.75
L1	-	1.00REF	-
$\theta$	0	-	7°

Figure 6-4: LQFP64–64 pin, 10 x 10 mm low-profile quad flat package recommended footprint

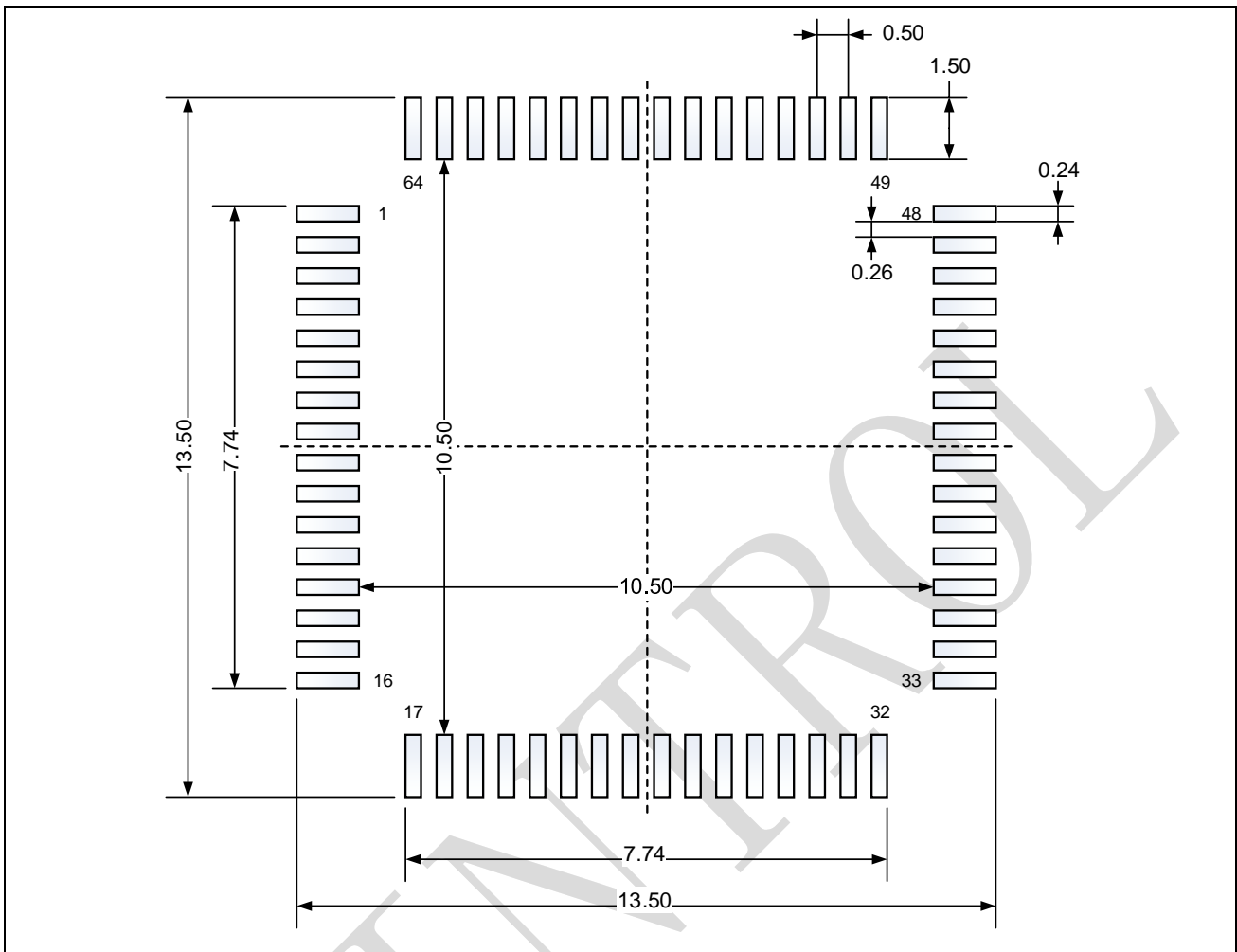

[1] Dimensions are expressed in millimeters.

### 6.3 LQFP52

Figure 6-5: LQFP52–52 pin, 14 x 14 mm low-profile quad flat package outline

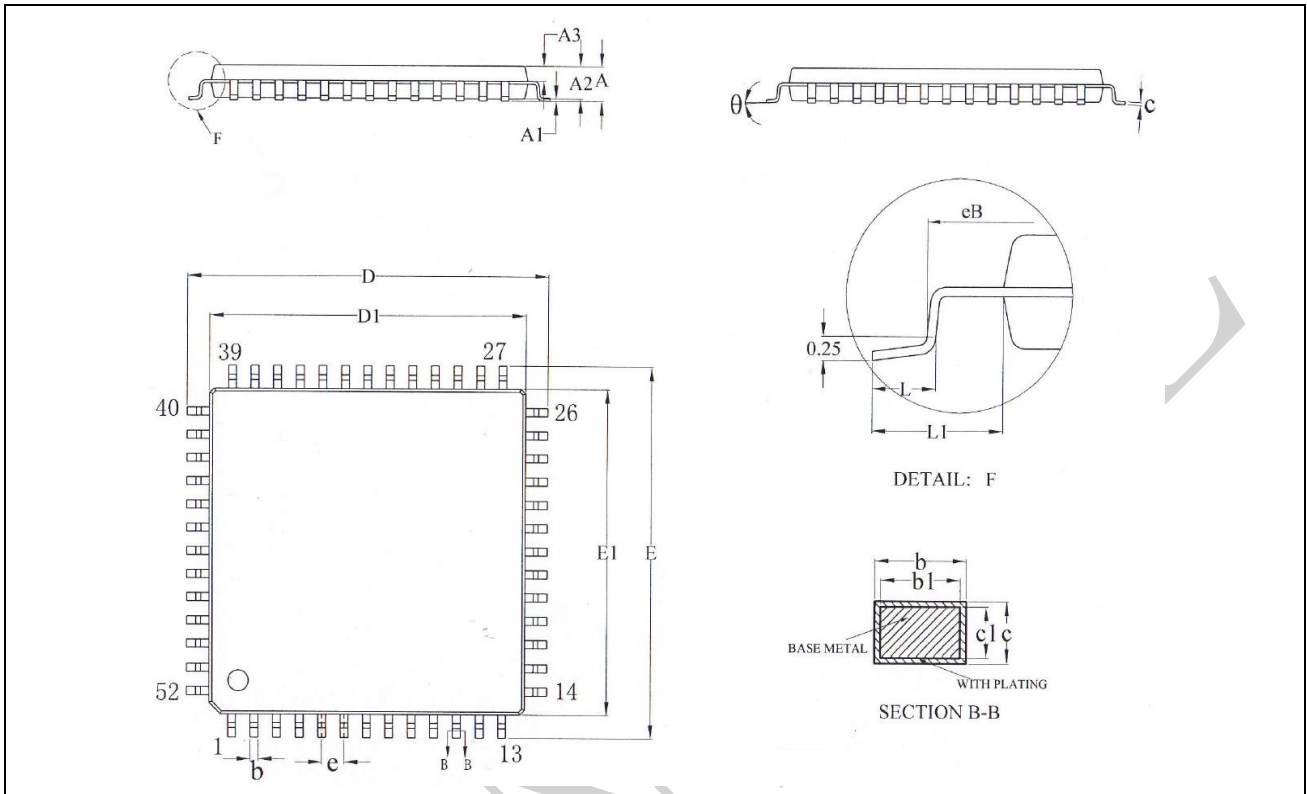

[1] Drawing is not to scale.

Table 6-3: LQFP52–52 pin, 14 x 14 mm low-profile quad flat package mechanical data

Symbol	millimeters		
	Min	Typ	Max
A	-	-	1.60
A1	0.05	-	0.15
A2	1.35	1.40	1.45
A3	0.59	0.64	0.69
b	0.38	-	0.46
b1	0.37	0.40	0.43
c	0.13	-	0.17
c1	0.12	0.13	0.14
D	15.80	16.00	16.20
D1	13.90	14.00	14.10
E	15.80	16.00	16.20
E1	13.90	14.00	14.10
eB	15.05	-	15.35
e	-	1.00	-
L	0.45	-	0.75

Symbol	millimeters		
	Min	Typ	Max
L1	-	1.00REF	-
$\theta$	0	-	7°

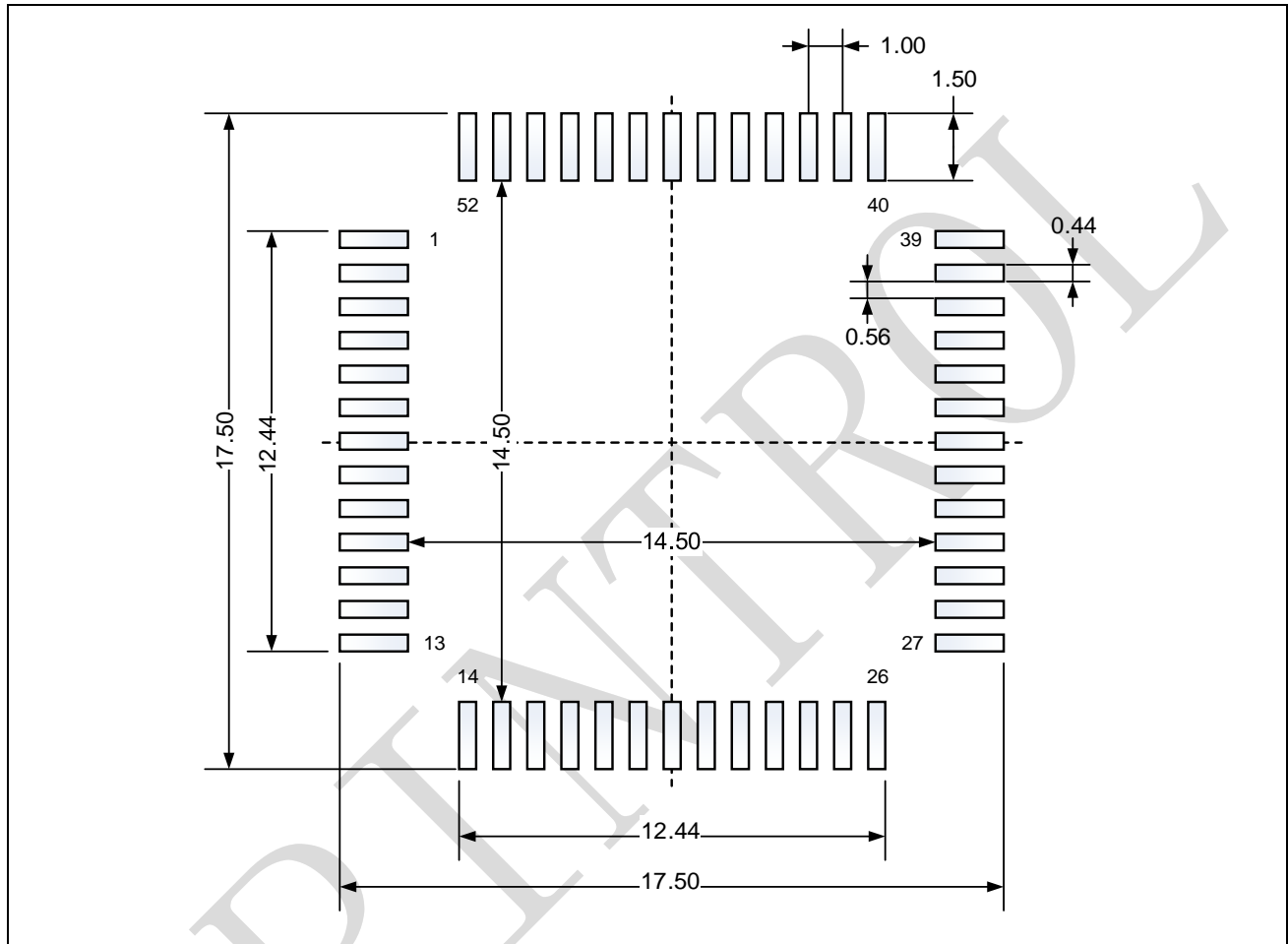
**Figure 6-6: LQFP52–52 pin, 14 x 14 mm low-profile quad flat package recommended footprint**

[1] Dimensions are expressed in millimeters.

### 6.4 LQFP48

Figure 6-7: LQFP48–48 pin, 7 x 7 mm low-profile quad flat package outline

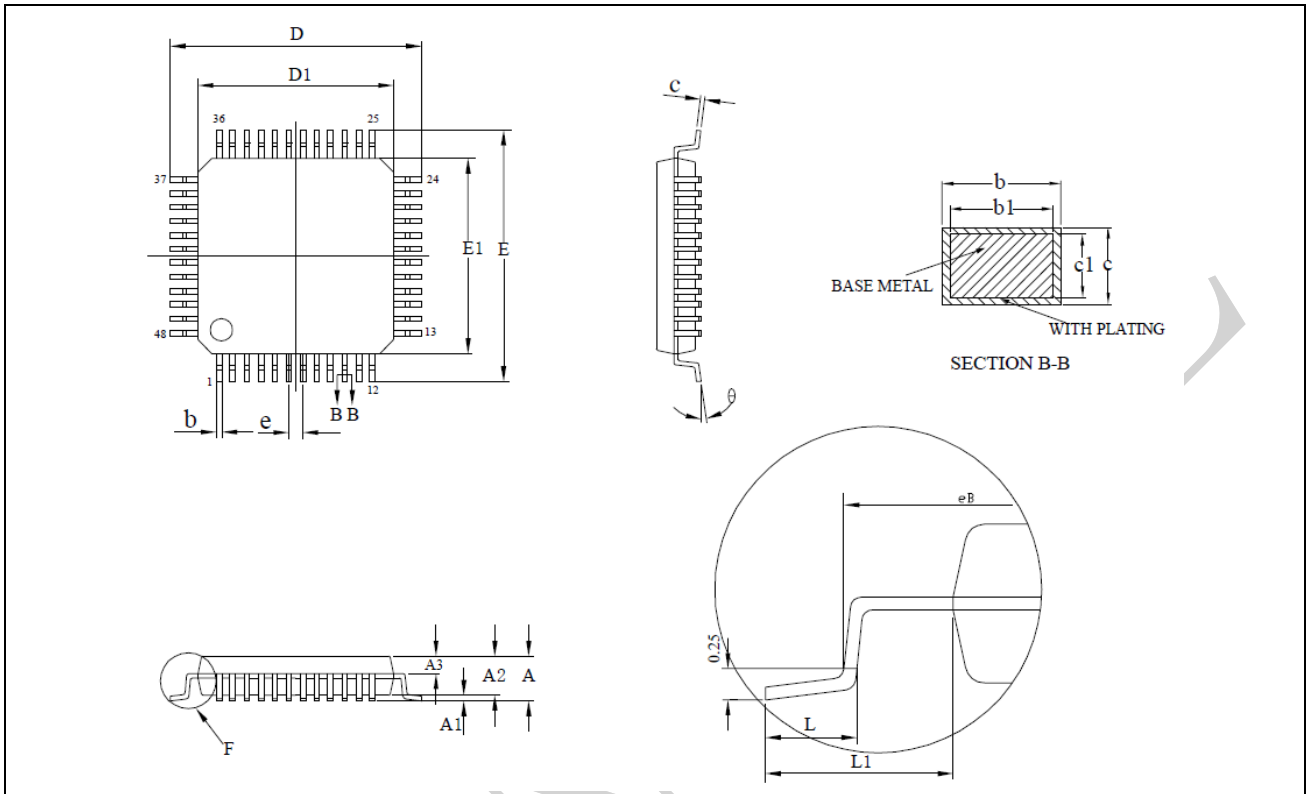

[1] Drawing is not to scale.

Table 6-4: LQFP48–48 pin, 7 x 7 mm low-profile quad flat package mechanical data

Symbol	millimeters		
	Min	Typ	Max
A	-	-	1.60
A1	0.05	-	0.15
A2	1.35	1.40	1.45
A3	0.59	0.64	0.69
b	0.19	-	0.27
b1	0.18	0.20	0.23
c	0.13	-	0.18
c1	0.12	0.13	0.14
D	8.80	9.00	9.20
D1	6.90	7.00	7.10
E	8.80	9.00	9.20
E1	6.90	7.00	7.10
eB	8.10	-	8.25
e	-	0.5	-
L	0.4	-	0.75

Symbol	millimeters		
	Min	Typ	Max
L1	-	1.00	-
$\theta$	0	-	7°

Figure 6-8: LQFP48–48 pin, 7 x 7 mm low-profile quad flat package recommended footprint

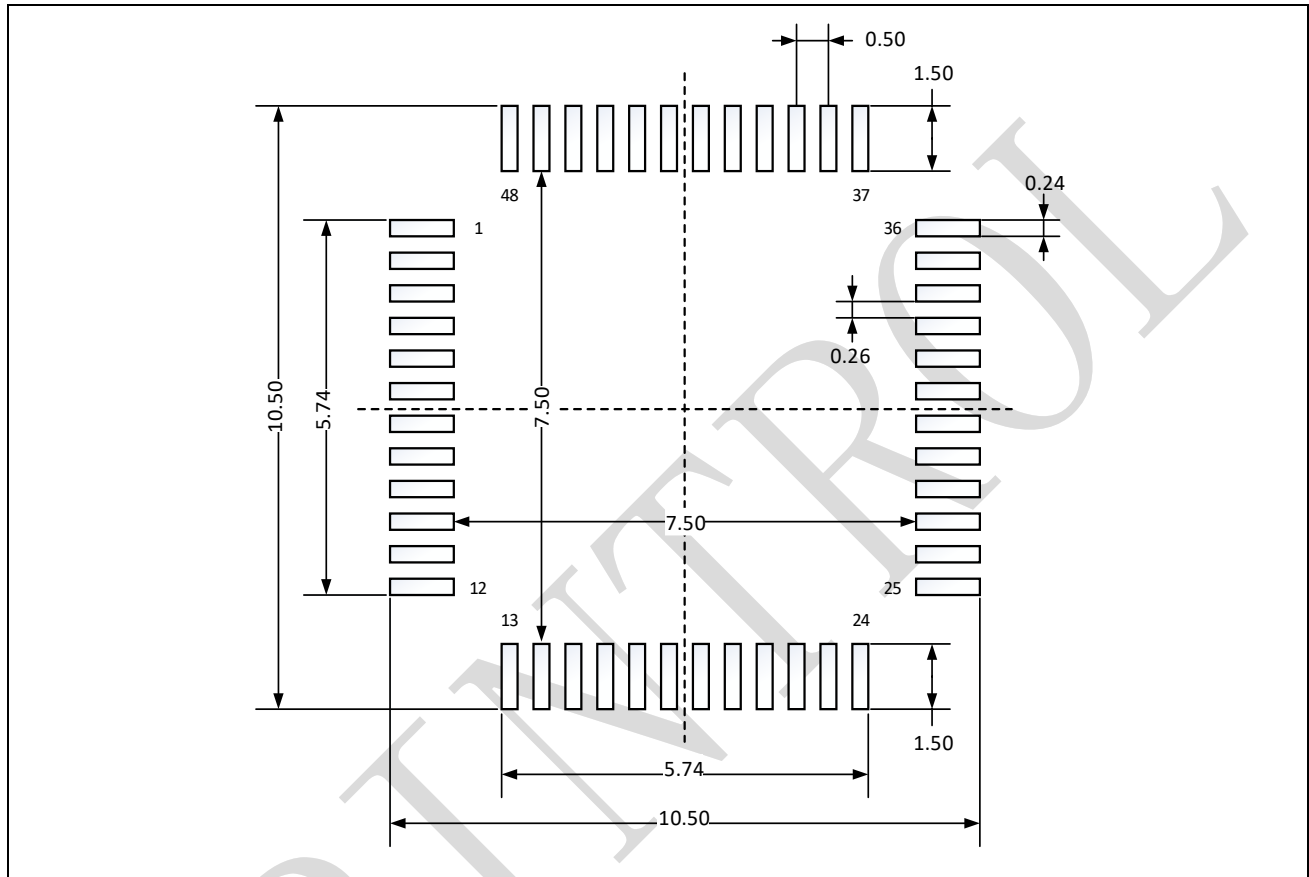

[1] Dimensions are expressed in millimeters.

## 6.5 QFN52

Figure 6-9: QFN52–52 pin, 6 x 6 mm quad flat no-lead package outline

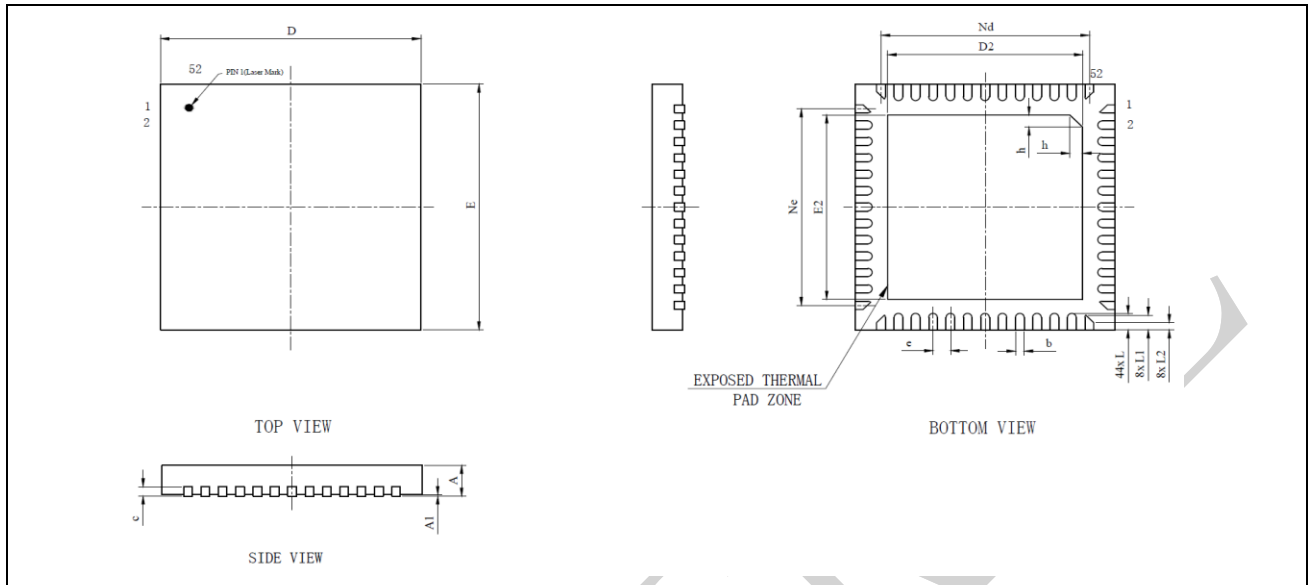

[1] Drawing is not to scale.

Table 6-5: QFN52–52 pin, 6 x 6 mm quad flat no-lead package mechanical data

Symbol	millimeters		
	Min	Typ	Max
A	0.70	0.75	0.80
A1	-	0.035	0.05
b	0.15	0.20	0.25
c	0.18	0.20	0.25
D	5.90	6.00	6.10
D2	4.40	4.50	4.60
e	0.40		
Nd	4.80		
E	5.90	6.00	6.10
E2	4.40	4.50	4.60
Ne	4.80		
L	0.35	0.40	0.45
L1	0.31	0.36	0.41
L2	0.13	0.18	0.23
h	0.25	0.30	0.35

**Figure 6-10: QFN52–52 pin, 6 x 6 mm quad flat no-lead package recommended footprint**

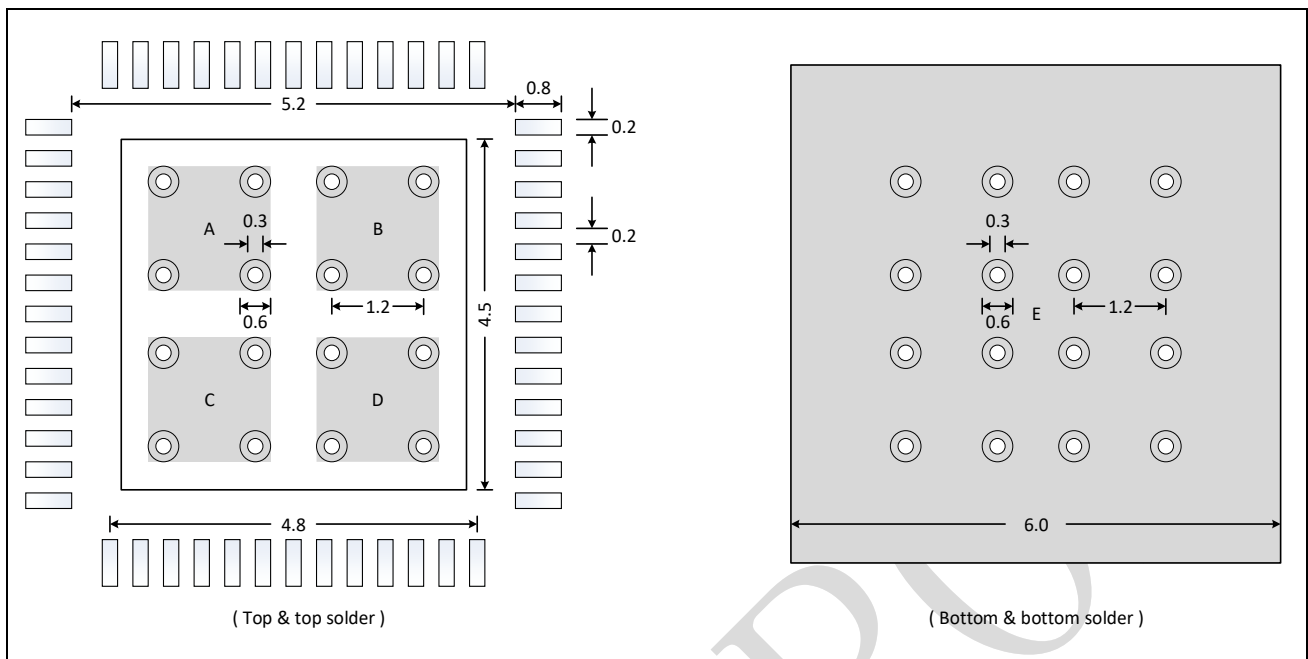

- [1] Dimensions are expressed in millimeters.
- [2] The A, B, C, D areas on the top layer should brush solder paste, and E area on bottom layer can either brush solder paste or not.



## 7 Ordering information

Table 7-1: Ordering information

Ordering Number	Flash	SRAM	Max CPU Frequency	Package	Temperature Range	SPQ <sup>(1)</sup>	Packing
SPC1198APE80	512KB	80KB	200MHz	LQFP80	Industrial -40 °C to +125 °C	1190	Tray
SPC1198APE64 <sup>(2)</sup>	512KB	80KB	200MHz	LQFP64	Industrial -40 °C to +125 °C	1600	Tray
SPC1198LAPE64	256KB	80KB	200MHz	LQFP64	Industrial -40 °C to +125 °C	1600	Tray
SPC1198APE52 <sup>(3)</sup>	512KB	80KB	200MHz	LQFP52	Industrial -40 °C to +125 °C	900	Tray
SPC1198APE48 <sup>(4)</sup>	512KB	80KB	200MHz	LQFP48	Industrial -40 °C to +125 °C	2500	Tray
SPC1198LAPE48	256KB	80KB	200MHz	LQFP48	Industrial -40 °C to +125 °C	2500	Tray
SPC1198API52	512KB	80KB	200MHz	QFN52	Industrial -40 °C to +125 °C	4900	Tray

[1] SPQ = Standard Pack Quantity.

[2] SPC1198APE64 is not officially on product line now and is subject to change.

[3] SPC1198APE52 is not officially on product line now and is subject to change.

[4] SPC1198APE48 is not officially on product line now and is subject to change.

### 7.1 Coding rule

Figure 7-1: Coding rule

